



**Red Hat Reference Architecture Series**

# **Deploying Oracle Database 11g R2 on Red Hat Enterprise Linux 6**

## **Best Practices**

Roger Lopez, Principal Software Engineer  
RHCE

Version 1.4  
December 2013





1801 Varsity Drive™  
Raleigh NC 27606-2072 USA  
Phone: +1 919 754 3700  
Phone: 888 733 4281  
Fax: +1 919 754 3701  
PO Box 13588  
Research Triangle Park NC 27709 USA

Linux is a registered trademark of Linus Torvalds. Red Hat, Red Hat Enterprise Linux and the Red Hat "Shadowman" logo are registered trademarks of Red Hat, Inc. in the United States and other countries.

Oracle and Java are registered trademarks of Oracle.

Intel, the Intel logo and Xeon are registered trademarks of Intel Corporation or its subsidiaries in the United States and other countries.

All other trademarks referenced herein are the property of their respective owners.

© 2013 by Red Hat, Inc. This material may be distributed only subject to the terms and conditions set forth in the Open Publication License, V1.0 or later (the latest version is presently available at <http://www.opencontent.org/openpub/>).

The information contained herein is subject to change without notice. Red Hat, Inc. shall not be liable for technical or editorial errors or omissions contained herein.

Distribution of modified versions of this document is prohibited without the explicit permission of Red Hat Inc.

Distribution of this work or derivative of this work in any standard (paper) book form for commercial purposes is prohibited unless prior permission is obtained from Red Hat Inc.

The GPG fingerprint of the [security@redhat.com](mailto:security@redhat.com) key is:  
CA 20 86 86 2B D6 9D FC 65 F6 EC C4 21 91 80 CD DB 42 A6 0E



## Comments and Feedback

In the spirit of open source, we invite anyone to provide feedback and comments on any reference architectures. Although we review our papers internally, sometimes issues or typographical errors are encountered. Feedback allows us to not only improve the quality of the papers we produce, but allows the reader to provide their thoughts on potential improvements and topic expansion to the papers.

Feedback on the papers can be provided by emailing [refarch-feedback@redhat.com](mailto:refarch-feedback@redhat.com). Please refer to the title within the email.

## Staying In Touch

Join us on some of the popular social media sites where we keep our audience informed on new reference architectures as well as offer related information on things we find interesting.

**Like us on Facebook:**

<https://www.facebook.com/rhrefarch>

**Follow us on Twitter:**

<https://twitter.com/RedHatRefArch>

**Plus us on Google+:**

<https://plus.google.com/u/0/b/114152126783830728030/>

## Accessing Reference Architectures

There are two ways to access Red Hat reference architectures:

- The Red Hat customer portal at <http://access.redhat.com> using a customer login
- The Red Hat resource library at <http://www.redhat.com/resourcelibrary/reference-architectures/>



# Table of Contents

1 Executive Summary.....	1
2 Reference Architecture Environment.....	2
2.1 Reference Architecture Overview.....	2
2.2 Network Topology.....	3
2.3 Hardware Details.....	4
2.4 File System Layout & Disk Space Details.....	5
2.5 Storage Layout.....	6
2.6 Swap Space.....	6
2.7 Security: Firewall Settings.....	7
2.8 Security: SELinux.....	7
3 Reference Architecture Configuration Details.....	8
3.1 Setting OS Hostname.....	8
3.2 Network Configuration.....	8
3.2.1 Configuring /etc/resolv.conf file.....	9
3.2.2 Public Network Configuration.....	9
3.2.3 NTP Configuration.....	11
3.3 OS Configuration.....	12
3.3.1 Accessing the RHN Repository.....	12
3.3.2 Oracle Database 11g Release 2 (11.2.0.3) Package Requirements.....	12
3.3.3 Configuring Security-Enhanced Linux (SELinux).....	14
3.3.4 Configuring Firewall Settings.....	14
3.3.5 Setting Virtual Memory.....	15
3.3.6 Setting Shared Memory.....	16
3.3.7 Setting Semaphores.....	17
3.3.8 Ephemeral Network Ports.....	18
3.3.9 Optimizing Network Settings.....	18
3.3.10 Increasing synchronous I/O Requests.....	19
3.3.11 Increasing File Handles.....	19
3.3.12 User Accounts & Groups.....	20
3.3.13 Setting Shell Limits for the Grid and Oracle User.....	21
3.4 Storage Configuration.....	23
3.4.1 Setting up DM-Multipath.....	23
3.4.2 Partitioning Device Mapper Shared Disks.....	26



3.4.3 Configuring Oracle ASM Disks.....	27
3.4.3.1 Oracle ASMLib Alternative: Configuring Udev Rules.....	27
3.4.3.2 Configuring Oracle ASMLib.....	28
3.4.4 Optimizing Database Storage using Automatic System Tuning.....	32
4 Oracle 11gR2 Configuration.....	34
4.1.1 Installing Oracle Grid Infrastructure (Required for ASM).....	34
4.1.2 Installing Oracle 11g R2 Database Software.....	38
4.1.3 Creating ASM Diskgroups via the ASM Configuration Assistant (ASMCA).....	43
4.1.4 Creating a Database using Database Configuration Assistant (DBCA).....	45
4.1.5 Enabling HugePages.....	50
5 Logging into the Oracle Database 11g Release 2 (11.2.0.3).....	52
6 Conclusion.....	53
Appendix A: Revision History.....	54
Appendix B: Contributors .....	55
Appendix C: DM Multipath Configuration File.....	56
Appendix D: Iptables Configuration File.....	58
Appendix E: Huge Pages Script.....	59
Appendix F: Oracle Database Package Requirements Text File.....	60
Appendix G: Kernel Parameters.....	61
Appendix H: Limits Configuration File (99-grid-oracle-limits.conf).....	62
Appendix I: 99-oracle-asmdevices.rules.....	63
Appendix J: Sample Kickstart File.....	64
Appendix K: Configuration Files.....	65
Appendix L: Troubleshooting ORA-* Errors.....	66
Appendix M: References.....	70

# 1 Executive Summary

IT organizations face challenges of optimizing Oracle database environments to keep up with the ever increasing workload demands and evolving security risks. This reference architecture provides a step-by-step deployment procedure with the latest best practices to install and configure an Oracle Database 11g Release (11.2.0.3) with Oracle Automatic Storage Management (ASM). It is suited for system, storage, and database administrators deploying Oracle Database 11g Release 2 (11.2.0.3) on Red Hat Enterprise Linux 6. It is intended to provide a Red Hat | Oracle reference architecture that focuses on the following tasks:

- Deploying Oracle Grid Infrastructure 11g R2 (11.2.0.3)
- Deploying Oracle Database 11g R2 (11.2.0.3) with shared SAN disks
- Using Oracle ASM disks with *udev* rules or with Oracle ASMLib
- Securing the Oracle Database 11gR2 environment with *SELinux*



## 2 Reference Architecture Environment

This section focuses on the components used during the deployment of Oracle Database 11g Release 2 (11.2.0.3) with Oracle Automatic Storage Management (ASM) on Red Hat Enterprise Linux 6 x86\_64 in this reference architecture.

### 2.1 Reference Architecture Overview

A pictorial representation of the environment used in this reference architecture is shown in **Figure 1: Reference Architecture Overview**.

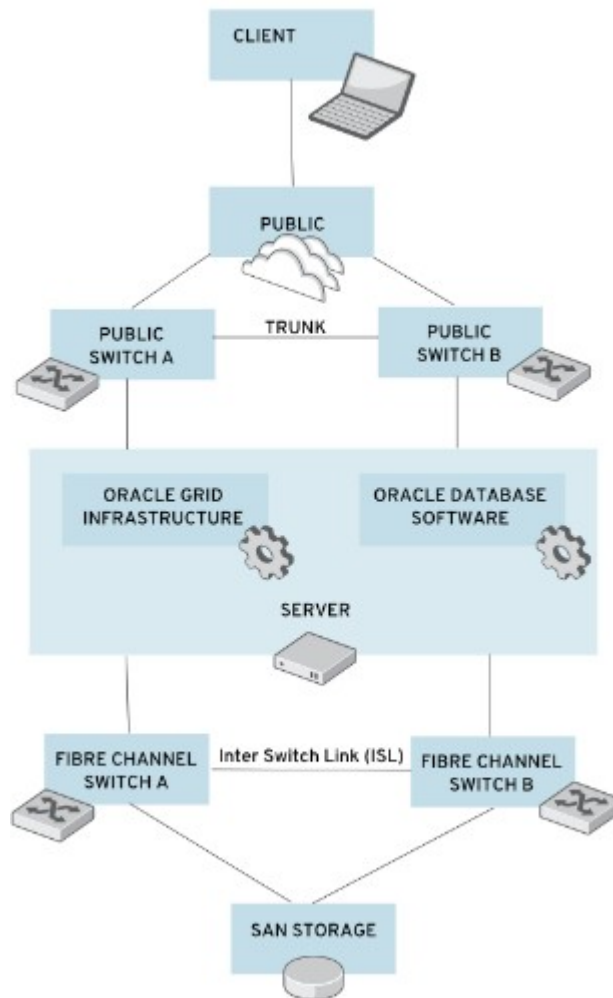

**Figure 1: Reference Architecture Overview**

## 2.2 Network Topology

The network topology used in this reference architecture consists of two public switches with a link aggregation that connect the two switches together (*Public Switch A* and *Public Switch B*), creating a single logical switch. Ethernet device *em1* on the server connects to *Public Switch A*, while Ethernet device *em2* on the server connects to *Public Switch B*. Ethernet devices *em1* and *em2* are bonded together as a bond device, *bond0*, providing high availability for the network traffic. **Figure 2.2.1: Network Topology** shows the pictorial representation of the two public switches connecting to the server, while **Figure 2.2.2: Ethernet Bonding** shows the bonding of Ethernet device *em1* and *em2* as part of the *bond0* device.

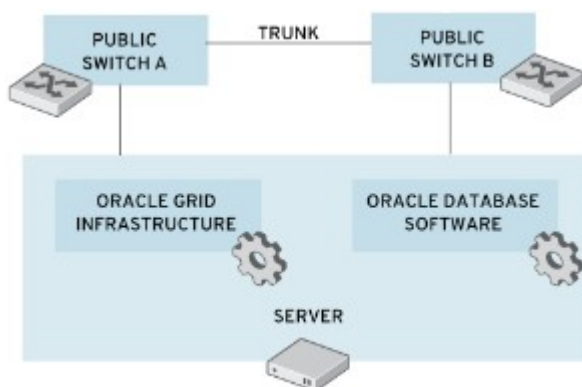

**Figure 2.2.1: Network Topology**

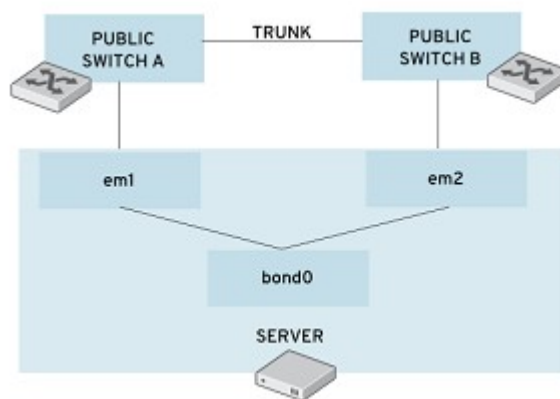

**Figure 2.2.2: Ethernet Bonding**





## 2.3 Hardware Details

The following are the minimum hardware requirements to properly install Oracle Database 11g Release 2 (11.2.0.3) on a x86\_64 system:

- Minimum of 1 GB of RAM for the installation of both Oracle Grid Infrastructure and Oracle Database, however 2 GB of memory or more is recommended
- Minimum of 1 Network Interface Card (NIC), however 2 NICs are recommended for high availability (HA) as used in the reference architecture
- Red Hat Enterprise Linux 6.x Server x86\_64 with kernel 2.6.32-71 or higher
- Console access that supports 1024 x 768 resolution to ensure correct display of Oracle's Universal Installer (OUI).

**Table 2.3.1: Server Details** specifies the hardware for the server used within this reference architecture. This hardware meets the minimum requirements for properly installing Oracle Database 11g Release 2 (11.2.0.3) on a x86\_64 system.

Server Hardware	Specifications
<b>Oracle 11g R2 Standalone Server</b> (db-oracle-node1) [1 x HP ProLiant DL370 G6 Server]	Red Hat Enterprise Linux 6.4 kernel 2.6.32-358.el6.x86_64
	2 Socket, 8 Core (16 cores) Intel(R) Xeon(R) CPU W5580 @ 3.20 GHz
	48 GB of memory, DDR3 4096 MB @ 1333 MHz DIMMs
	2 x NetXen NX3031 1/10-Gigabit Network Interface Cards (NICs) for public network
	1 x Qlogic ISP2532 8GB Fibre Channel Dual Port HBA

**Table 2.3.1: Server Details**

**Table 2.3.2: Switch Details** specifies the Fibre Channel and Ethernet switches used within this reference architecture.

Switch Hardware
2 x Brocade Silkworm Fibre Switches
2 x HP ProCurve Gigabit Switches

**Table 2.3.2: Switch Details**

**Table 2.3.3: Storage Details** specifies the storage used for storing Oracle data files within this reference architecture.

Storage Hardware	Specifications
HP StorageWorks MSA2324fc Dual Controller Array	24 x 146 GB 15K SAS Hard disks

**Table 2.3.3: Storage Details**

## 2.4 File System Layout & Disk Space Details

The following are the minimum disk space requirements for properly installing Oracle Database 11g Release 2 (11.2.0.3) software based upon this reference architecture.

Software	Disk Space
Oracle Grid Infrastructure Home	5.5 GB
Oracle Database Home Enterprise Edition (includes software files and data files)	8.9 GB
/tmp	1 GB

**Table 2.4.1: Disk Space Requirements**

**NOTE:** The actual amount of disk space consumed for Oracle Grid Infrastructure Home and Oracle Database Home Enterprise Edition may vary.

**Table 2.4.2: File System Layout** specifies the file system layout for the server used within this reference architecture. This layout ensures the disk space requirements to properly install the Oracle Grid Infrastructure and Oracle Database software for Oracle Database 11g Release 2 (11.2.0.3) within the /u01 partition.

File System Layout	Disk Space Size
/	15 GB
/dev/shm	24 GB
/boot	248 MB
/home	8 GB
/tmp	4 GB
/u01	50 GB
/usr	5 GB
/var	8 GB

**Table 2.4.2: File System Layout**

While the size of the Oracle data files varies for each solution, the following are the Oracle



data file sizes used for this reference architecture.

Volume	Volume Size
Oracle Database Volume 1 (db1)	100 GB
Oracle Database Volume 2 (db2)	100 GB
Fast Recovery Area (fra)	200 GB
Oracle Redo Log Volume (redo)	10 GB

**Table 2.4.3: Oracle Data File Sizes for Reference Architecture**

## 2.5 Storage Layout

**Table 2.5.1: Storage Disk Layout for Reference Architecture** shows the storage disk layout for each volume.

Virtual Diskgroup Name	Volume Name	Volume Size	RAID Group Type	Harddrive Count	Hot Spares Available	Size of Virtual Disk
vd01	db1	100 GB	Raid 1/0	8	1	586 GB
vd02	db2	100 GB	Raid 1/0	8	1	586 GB
vd03	fra	200 GB	Raid 5	5	0	586 GB
vd04	redo	10 GB	Raid 1	2	0	146 GB

**Table 2.5.1: Storage Disk Layout for Reference Architecture**

## 2.6 Swap Space

Swap space is determined by the amount of RAM found within the system. The following table displays the swap space recommendation. This reference architecture allocates 16 GB of RAM for swap space.

RAM	Swap Space
2.5 GB up to 16 GB	Equal to the size of RAM
Greater than 16 GB	16 GB of RAM

**Table 2.6.1: Recommended Swap Space**

**NOTE:** When calculating swap space, ensure not to include RAM assigned for *hugepages*. More information on *hugepages* can be found in **Section 4.1.5 Enabling HugePages**

## 2.7 Security: Firewall Settings

**Table 2.7.1: Firewall Settings** lists the enabled ports within this reference architecture.

Port	Protocol	Description
22	TCP	Secure Shell (SSH)
80	TCP	Hypertext Transfer Protocol (HTTP)
443	TCP	Hypertext Transfer Protocol over SSL/TLS (HTTPS)
1521	TCP	Oracle Transparent Network Substrate (TNS) Listener default port
1158	TCP	Oracle Enterprise Manager 11g default port

**Table 2.7.1: Firewall Settings**

## 2.8 Security: SELinux

Oracle 11g Release 2 version 11.2.0.3 and later support *SELinux*. All systems in this reference architecture run with *SELinux* enabled and set to enforcing mode. **Table 2.8.1: SELinux Packages** lists the required *SELinux* packages. The version 3.7.19-202 is available within the downloadable tar from **Appendix K Configuration Files**

Package	Version
selinux-policy	3.7.19-211
selinux-policy-targeted	3.7.19-211

**Table 2.8.1: SELinux Packages**



# 3 Reference Architecture Configuration Details

This reference architecture focuses on the deployment of Oracle Database 11g Release 2 (11.2.0.3) with Oracle Automatic Storage Management (ASM) on Red Hat Enterprise Linux 6 x86\_64. The configuration is intended to provide a comprehensive Red Hat | Oracle solution. The key solution components covered within this reference architecture consists of:

- Red Hat Enterprise Linux 6 Update 4
- Oracle Grid Infrastructure 11g Release 2 (11.2.0.3)
- Oracle Database 11g Release 2 (11.2.0.3)
- Security-Enhanced Linux (SELinux)
- Device Mapper Multipathing
- *udev* Rules
- Oracle ASMLib

## 3.1 Setting OS Hostname

A unique host name is required for the installation of Oracle Database 11g Release 2 (11.2.0.3) The host name within this reference architecture is: *db-oracle-node1*. To set the host name, please follow the instructions below.

Set the host name via the use of the **hostname** command. An example of setting *db-oracle-node1* host name is shown below.

```
# hostname db-oracle-node1.cloud.lab.eng.bos.redhat.com
```

Edit the */etc/sysconfig/network* file's host name variable with the host name provided above. An example of the */etc/sysconfig/network* file on *db-oracle-node1* can be seen below.

```
# cat /etc/sysconfig/network
NETWORKING=yes
HOSTNAME=db-oracle-node1.cloud.lab.eng.bos.redhat.com
NOZEROCONF=yes
```

## 3.2 Network Configuration

The network configuration section focuses on the proper creation of a bonded network interface, ensures the *NetworkManager* is disabled, and configures the */etc/resolv.conf* file. The bonded network interface provides an Oracle environment with high availability in case of a network interface failure.

## 3.2.1 Configuring `/etc/resolv.conf` file

Via the man pages of `resolv.conf`, “The resolver is a set of routines in the C library that provide access to the Internet Domain Name System (DNS). The resolver configuration file contains information that is read by the resolver routines the first time they are invoked by a process. The file is designed to be human readable and contains a list of keywords with values that provide various types of resolver information.” The `/etc/resolv.conf` file for this reference architecture consists of two configuration options: `nameserver` and `search`. The `search` option is used to search for a host name part of a particular domain. The `nameserver` option is the IP address of the name server the system (`db-oracle-node1`) should query. If more than one `nameserver` is listed, the resolver library queries them in order. An example of the `/etc/resolv.conf` file used on the reference architecture can be seen below.

```
cat /etc/resolv.conf
search cloud.lab.eng.bos.redhat.com
nameserver 10.16.143.247
nameserver 10.16.143.248
nameserver 10.16.255.2
```

For more information, please visit the man pages of the `resolv.conf` file via the command:

```
# man resolv.conf
```

## 3.2.2 Public Network Configuration

The public network configuration consists of two network interfaces bonded together to provide high availability. The example below shows how to bond physical interfaces `em1` and `em2` with a bond device labeled `bond0`. If `NetworkManager` is installed, ensure it is *disabled*.

Check the status of `NetworkManager`:

```
# chkconfig --list | grep NetworkManager
NetworkManager 0:off 1:off 2:off 3:off 4:off 5:off 6:off
```

Disable `NetworkManager`:

```
# service NetworkManager stop
# chkconfig NetworkManager off
```

As the root user, execute the following command which creates a file named `bonding.conf` within the `/etc/modprobe.d/` directory needed to create a bonded device for multiple network interfaces. The `bonding.conf` file is also part of **Appendix K Configuration Files**

```
# echo "alias bond0 bonding" > /etc/modprobe.d/bonding.conf
```



As the root user, create a backup of the *ifcfg-em1* & *ifcfg-em2* files, create the *ifcfg-bond0* file and edit the *ifcfg-em1* & *ifcfg-em2* configuration files found within */etc/sysconfig/network-scripts*. An example can be seen below.

```
# cp /etc/sysconfig/network-scripts/ifcfg-em1 /etc/sysconfig/network-  
scripts/ifcfg-em1.bkup  
# cp /etc/sysconfig/network-scripts/ifcfg-em2 /etc/sysconfig/network-  
scripts/ifcfg-em2.bkup
```

```
# cat /etc/sysconfig/network-scripts/ifcfg-bond0
```

```
DEVICE="bond0"  
BONDING_OPTS="mode=1 miimon=100 primary=em1"  
NM_CONTROLLED="no"  
IPADDR="10.16.142.51"  
NETMASK="255.255.248.0"  
GATEWAY="10.16.143.254"  
ONBOOT="yes"
```

```
# cat /etc/sysconfig/network-scripts/ifcfg-em1
```

```
DEVICE="em1"  
BOOTPROTO="none"  
HWADDR="00:25:B3:A8:6F:18"  
IPV6INIT="no"  
NM_CONTROLLED="no"  
ONBOOT="yes"  
TYPE="Ethernet"  
UUID="3db45d28-e63c-401b-906a-ef095de4fc1e"  
SLAVE="yes"  
MASTER="bond0"
```

```
# cat /etc/sysconfig/network-scripts/ifcfg-em2
```

```
DEVICE="em2"  
BOOTPROTO="none"  
HWADDR="00:25:B3:A8:6F:19"  
IPV6INIT="no"  
NM_CONTROLLED="no"  
ONBOOT="yes"  
TYPE="Ethernet"  
UUID="7d29d87f-52bb-4dc6-88ca-d0857c7d7fd9"  
SLAVE="yes"  
MASTER="bond0"
```

After all the network scripts are configured, restart the network service via the command:

```
# service network restart  
Shutting down interface bond0: [ OK ]  
Shutting down loopback interface: [ OK ]  
Bringing up loopback interface: [ OK ]  
Bringing up interface bond0: [ OK ]
```

### 3.2.3 NTP Configuration

The **ntpd** program is an operating system daemon which sets and maintains the system time of day in synchronism with Internet standard time servers<sup>1</sup>. The **ntpd** program operates by exchanging messages with one or more configured servers at designated poll intervals<sup>1</sup>.

To configure the **ntpd** daemon, follow the instructions below.

1. Edit the `/etc/ntp.conf` file with a text editor such as **vi**.

```
# vi /etc/ntp.conf
```

2. Locate the following public server pool section, and modify to include the appropriate NTP servers. For the purposes of this reference architecture, only one NTP server is used, but 3 is recommended. The **iburst** option was added to speed up the time in which it takes to properly sync with the NTP servers.

```
# Use public servers from the pool.ntp.org project.
# Please consider joining the pool (http://www.pool.ntp.org/join.html).
server 10.16.255.2 iburst
```

3. Save all the changes within the `/etc/ntp.conf` file
4. Restart the **ntpd** daemon via the command:

```
# service ntpd restart
Shutting down ntpd:                [FAILED]
Starting ntpd:                      [ OK ]
```

**NOTE:** Shutting down **ntpd** daemon provides a status of 'FAILED' if the **ntpd** daemon is currently off.

5. Ensure that the **ntpd** daemon is started when the system is booted.

```
# chkconfig ntpd on
```

---

<sup>1</sup> `ntpd` – Network Time Protocol (NTP) daemon man page – `man ntpd (8)`





## 3.3 OS Configuration

### 3.3.1 Accessing the RHN Repository

Instructions on how to register a system and manage subscriptions on Red Hat Enterprise Linux 6 can be found within the Red Hat Linux 6 Deployment Guide documentation<sup>2</sup>.

The following table shows the required channels via the Red Hat Network for the installation of Oracle.

Channel	Source
rhel-x86_64-server-6	RHN Classic
rhel-x86_64-server-supplementary-6	RHN Classic

**Table 3.3.1.1: Required Channels**

**NOTE:** The rhel-x86\_64-server-supplementary-6 channel is a requirement for the implementation of Oracle *ASMLib* found in **Section 3.4.3.2 Configuring Oracle ASMLib**. However, Oracle *ASMLib* is not required for the use of Oracle ASM disks. This reference architecture features both methods of implementation within **Section 3.4.3.1 Oracle ASMLib Alternative: Configuring Udev Rules** and **Section 3.4.3.2 Configuring Oracle ASMLib**

### 3.3.2 Oracle Database 11g Release 2 (11.2.0.3) Package Requirements

A specific set of packages is required to properly deploy Oracle Database 11g Release 2 (11.2.0.3) on Red Hat Enterprise Linux 6 (x86\_64). The number of installed packages required varies depending on whether a default or minimal installation of Red Hat Enterprise Linux 6 (x86\_64) is performed. For the purposes of this reference architecture, a minimal Red Hat Enterprise Linux 6 installation is performed to reduce the number of installed packages. A sample kickstart file as been provided within **Appendix K Configuration Files**. Red Hat Enterprise Linux 6 installation required group packages:

Required Group Packages
@Base
@Core

**Table 3.3.2.1: Group Packages**

<sup>2</sup> Red Hat Enterprise Linux 6 Deployment Guide, [https://access.redhat.com/site/documentation/en-US/Red\\_Hat\\_Enterprise\\_Linux/6/html-single/Deployment\\_Guide/index.html#entitlements](https://access.redhat.com/site/documentation/en-US/Red_Hat_Enterprise_Linux/6/html-single/Deployment_Guide/index.html#entitlements)

Oracle Grid Infrastructure 11.2 and Oracle Database 11.2 required x86\_64 RPM packages<sup>3</sup>:

Required Packages	
cloog-ppl	libXxf86misc
compat-libcap1	libXxf86vm
compat-libstdc++-33	libaio-devel
cpp	libdmx
gcc	libstdc++-devel
gcc-c++	mpfr
glibc-devel	make
glibc-headers	ppl
kernel-headers	xorg-x11-utils
libXmu	xorg-x11-xauth
libXt	libXv
ksh	libXxf86dga

**Table 3.3.2.2: Required Packages**

After the installation of Red Hat Enterprise Linux 6 is completed, create a file, *req-rpm.txt*, that contains the name of each RPM package listed above on a separate line. For simplicity, this *req-rpm.txt* file is included in **Appendix F Oracle Database Package Requirements Text File**.

Use the **yum** package manager to install the packages and any of their dependencies with the following command:

```
# yum install `awk '{print $1}' ./req-rpm.txt`
```

A minimum installation of Red Hat Enterprise Linux 6 does not install the *X Window System* server package, but only the required *X11* client libraries. In order to run the Oracle Universal Installer (OUI), a system with the *X Window System* server package installed is required. Via a system with *X Window System* installed, **SSH** into the Oracle Database server with the *Y* option to ensure trusted *X11* forwarding is set. The command is as follows:

```
# ssh -Y 10.16.142.51
```

Alternatively, if a system with the *X Window System* server package is unavailable, install the *X Window System* server package directly on the Oracle Database Server.

```
# yum groupinstall "X Window System"
```

<sup>3</sup> Linux OS Installation with Reduced Set of Packages for Running Oracle Database Server [ID 728346.1]



### 3.3.3 Configuring Security-Enhanced Linux (SELinux)

*SELinux* is an implementation of a mandatory access control (MAC) mechanism developed by the National Security Agency (NSA). The purpose of *SELinux* is to apply rules on files and processes based on defined policies. When policies are appropriately defined, a system running *SELinux* enhances application security by determining if an action from a particular process should be granted thus protecting against vulnerabilities within a system. The implementation of Red Hat Enterprise Linux 6 enables *SELinux* by default and appropriately sets it to the default setting of *ENFORCING*. It is highly recommended that *SELinux* be kept in *ENFORCING* mode when running Oracle Database 11g Release 2 (11.2.0.3).

Verify that *SELinux* is running and set to *ENFORCING*:

As the root user,

```
# getenforce
Enforcing
```

If the system is running in *PERMISSIVE* or *DISABLED* mode, modify the `/etc/sysconfig/selinux` file and set *SELinux* to enforcing as shown below.

```
SELINUX=enforcing
```

The modification of the `/etc/sysconfig/selinux` file takes effect after a reboot. To change the setting of *SELinux* immediately without a reboot, run the following command:

```
# setenforce 1
```

For more information on Security-Enhanced Linux, please visit the [Red Hat Enterprise Linux 6 Security-Enhanced Linux User Guide](#)

### 3.3.4 Configuring Firewall Settings

Firewall access and restrictions play a critical role in securing your Oracle Database 11g Release 2 (11.2.0.3) environment. It is recommended that the firewall settings be configured to permit access to the Oracle Database network ports only from authorized database or database-management clients. For example, in order to allow access to a specific database client with an IP address of 10.16.142.54 to make requests to the database server via SQL\*Net using Oracle's TNS (Transparent Network Substrate) Listener (default port of 1521), the following firewall rule must be added to the `iptables` configuration file found at `/etc/sysconfig/iptables`.

```
-A INPUT -m state --state NEW -m tcp -p tcp -s 10.16.142.54 --dport 1521 -j
ACCEPT
```

Likewise, if this particular database client with an IP address of 10.16.142.54 required access to the web-based Oracle Enterprise Manager 11g that uses the default port of 1158, the following firewall rule must be added to the `iptables` configuration file found at `/etc/sysconfig/iptables`.

```
-A INPUT -m state --state NEW -m tcp -p tcp -s 10.16.142.54 --dport 1158 -j ACCEPT
```

Once the rules have been modified within the `/etc/sysconfig/iptables`, run the following command to activate:

```
# service iptables restart
iptables: Flushing firewall rules: [ OK ]
iptables: Setting chains to policy ACCEPT: nat mangle filte [ OK ]
iptables: Unloading modules: [ OK ]
iptables: Applying firewall rules: [ OK ]
```

**NOTE:** A full listing of all the firewall settings within the `/etc/sysconfig/iptables` file for this reference architecture can be found at **Appendix D Iptables Configuration File**.

### 3.3.5 Setting Virtual Memory

Tuning virtual memory requires the modification of five kernel parameters that affect the rate at which virtual memory is used within Oracle databases. It is important to note the recommended values are to be used as a starting point when setting virtual memory. A brief description<sup>4</sup> and recommended settings for the virtual memory parameters, as well as, the definition of dirty data are described below.

*SWAPPINESS*<sup>4</sup> - A value from 0 to 100 which controls the degree to which the system swaps. A high value prioritizes system performance, aggressively swapping processes out of physical memory when they are not active. A low value prioritizes interactivity and avoids swapping processes out of physical memory for as long as possible, which decreases response latency. The default value is 60. The Oracle recommended value is 0.

*DIRTY DATA* – Dirty data is data that has been modified and held in the page cache for performance benefits. Once the data is flushed to disk, the data is clean.

*DIRTY\_RATIO*<sup>5</sup> – Contains, as a percentage of total system memory, the number of pages at which a process which is generating disk writes will itself start writing out dirty data. The default value is 20. The recommended value is 80.

*DIRTY\_BACKGROUND\_RATIO*<sup>5</sup> – Contains, as a percentage of total system memory, the number of pages at which the background write back daemon will start writing out dirty data. The Oracle recommended value is 3.

*DIRTY\_EXPIRE\_CENTISECS*<sup>5</sup> - Defines when dirty in-memory data is old enough to be eligible for writeout. The default value is 3000, expressed in hundredths of a second. The Oracle recommended value is 500.

*DIRTY\_WRITEBACK\_CENTISECS*<sup>5</sup> - Defines the interval of when writes of dirty in-memory data are written out to disk. The default value is 500, expressed in hundredths of a second. The Oracle recommended value is 100.

4 RHEL6 Kernel Documentation - `/usr/share/doc/kernel-doc-2.6.32/Documentation/sysctl/vm.txt`

5 RHEL6 Kernel Documentation - `/usr/share/doc/kernel-doc-2.6.32/Documentation/sysctl/vm.txt`



Prior to making any changes to the `/etc/sysctl.conf` ensure to create a backup as follows:

```
# cp /etc/sysctl.conf /etc/sysctl.conf.bkup
```

The following is a snippet from the `/etc/sysctl.conf` file with the five virtual memory parameters set with the recommended settings:

```
vm.swappiness = 0
vm.dirty_background_ratio = 3
vm.dirty_ratio = 80
vm.dirty_expire_centisecs = 500
vm.dirty_writeback_centisecs = 100
```

For the changes take effect immediately, run the following command:

```
# sysctl -p
```

**NOTE:** A full listing of all the kernel parameters modified within the `/etc/sysctl.conf` file can be found at **Appendix G Kernel Parameters**.

### 3.3.6 Setting Shared Memory

Shared memory allows processes to communicate with each other by placing regions of memory into memory segments. In the case of Oracle, shared memory segments are used by the System Global Area (SGA) to store incoming data and control information. The size of Oracle's SGA impacts the amount of shared memory pages and shared memory segments to be set within a system. By default, Red Hat Enterprise Linux 6 provides a large amount of shared memory pages and segments, however, the appropriate allocation for a system depends on the amount of RAM within the system.

In order to allocate the appropriate amount of shared memory pages and shared memory segments for a system running an Oracle database, the kernel parameters `SHMALL`, `SHMMAX`, and `SHMMNI` must be set.

`SHMALL` – is the maximum total amount of shared memory pages

`SHMMAX` – is the maximum size in bytes of a single shared memory segment

`SHMMNI` – is the maximum total amount of shared memory segments

The first step in determining the maximum amount of shared memory pages (`SHMALL`) in a system is to determine the system's page size in bytes. The following command can be used to obtain the system page size.

```
# getconf PAGE_SIZE
4096
```

Once the page size is captured, calculate `SHMALL` as follows:

$$TOTAL\ RAM\ IN\ BYTES / PAGE\_SIZE$$

For example, on a system with 48 GB of memory the `SHMALL` calculation would look as follows:

```
# echo "48 * 1024^3 / 4096" | bc
12582912
```

The calculation of *SHMMAX*, is as follows:

*HALF OF TOTAL RAM IN BYTES*

For example, on a system with 48 GB of memory the *SHMMAX* calculation would look as follows:

```
# echo "48 * 1024^3 / 2" | bc
25769803776
```

As for *SHMMNI*, Oracle recommends the value of *SHMMNI* to be set to 4096.

**NOTE:** If the current value found within */etc/sysctl.conf* for any parameter is higher than the value calculated for *SHMMAX* and *SHMALL*, do not change the value found within the */etc/sysctl.conf* file.

Since the values of *SHMMAX* and *SHMALL* calculated are smaller than the values already set, no changes are made within */etc/sysctl.conf*. Snippet of the */etc/sysctl.conf* file:

```
kernel.shmmax = 68719476736
kernel.shmall = 4294967296
kernel.shmmni = 4096
```

In order for the changes take effect immediately, run the following command:

```
# sysctl -p
```

**NOTE:** A full listing of all the kernel parameters modified within the */etc/sysctl.conf* file can be found at **Appendix G Kernel Parameters**.

### 3.3.7 Setting Semaphores

Red Hat Enterprise Linux 6 provides semaphores for synchronization of information between processes. The kernel parameter *sem* is composed of four parameters:

*SEMMSL* – is defined as the maximum number of semaphores per semaphore set

*SEMMNI* – is defined as the maximum number of semaphore sets for the entire system

*SEMMNS* – is defined as the total number of semaphores for the entire system

**NOTE:** *SEMMNS* is calculated by *SEMMSL* \* *SEMMNI*

*SEMOPM* – is defined as the total number of semaphore operations performed per *semop* system call.

The following line is required within the */etc/sysctl.conf* file to provide sufficient semaphores for Oracle:

```
kernel.sem = 250 32000 100 128
```

In order for the changes take effect immediately, run the following command:



```
# sysctl -p
```

**NOTE:** A full listing of all the kernel parameters modified within the */etc/sysctl.conf* file can be found at **Appendix G Kernel Parameters**.

### 3.3.8 Ephemeral Network Ports

Oracle recommends that the ephemeral default port range be set starting at 9000 to 65500. This ensures that all well known ports, ports used by Oracle and other applications are avoided. To set the ephemeral port range, modify the */etc/sysctl.conf* file and add the following line:

```
net.ipv4.ip_local_port_range = 9000 65500
```

In order for the changes take effect immediately, run the following command:

```
# sysctl -p
```

**NOTE:** A full listing of all the kernel parameters modified within the */etc/sysctl.conf* file can be found at **Appendix G Kernel Parameters**.

### 3.3.9 Optimizing Network Settings

Optimizing the network settings for the default and maximum buffers for the application sockets in Oracle Database 11g Release 2 (11.2.0.3) is done by setting static sizes to *RMEM* and *WMEM*. The *RMEM* parameter represents the receive buffer size, while the *WMEM* represents the send buffer size. The recommended values by Oracle are modified within the */etc/sysctl.conf* file.

```
net.core.rmem_default = 262144  
net.core.rmem_max = 4194304  
net.core.wmem_default = 262144  
net.core.wmem_max = 1048576
```

In order to make the changes take effect immediately, run the following command:

```
# sysctl -p
```

**NOTE:** A full listing of all the kernel parameters modified within the */etc/sysctl.conf* file can be found at **Appendix G Kernel Parameters**.

### 3.3.10 Increasing synchronous I/O Requests

The kernel parameter `FS.AIO-MAX-NR` sets the maximum number of on current asynchronous I/O requests. Oracle recommends setting the value to 1048576. In order to add `FS-AIO-MAX-NR` to 1048576, modify the `/etc/sysctl.conf` file as follows:

```
fs.aio-max-nr = 1048576
```

In order for the changes take effect immediately, run the following command:

```
# sysctl -p
```

**NOTE:** A full listing of all the kernel parameters modified within the `/etc/sysctl.conf` file can be found at **Appendix G Kernel Parameters**.

### 3.3.11 Increasing File Handles

**NOTE:** Oracle *ASMLib* does not open file descriptors for each device, but instead opens one file descriptor per Oracle process. This reference architecture features both methods of implementation within **Section 3.4.3.1 Oracle ASMLib Alternative: Configuring Udev Rules** and **Section 3.4.3.2 Configuring Oracle ASMLib**. However, during the installation of Oracle Database 11g Release 2 (11.2.0.3) the `FS.FILE-MAX` kernel parameter must be set to at least 6815744.

The kernel parameter `FS.FILE-MAX` sets the maximum number of open file handles assigned to the Red Hat Enterprise Linux 6 operating system. Oracle recommends that for each Oracle database instance found within a system, allocate  $512 * PROCESSES$  in addition to the open file handles already assigned to the Red Hat Enterprise Linux 6 operating system.

*PROCESSES* within a database instance refers to the maximum number of processes that can be concurrently connected to the Oracle database by the `oracle` user. The default value for *PROCESSES* is 150 for Oracle Database 11g Release 2 (11.2.0.3). To properly calculate the `FS.FILE-MAX` for a system, first identify the current `FS.FILE-MAX` allocated to the system via the following command:

```
# cat /proc/sys/fs/file-max  
32768
```

Next, add all the *PROCESSES* together from each Oracle database instance found within the system and multiple by 512 as seen in the following command.

```
# echo "512 * 150" | bc  
76800
```

**NOTE:** To determine the current *PROCESSES* value, log into the Oracle database instance and run the following command below. Since no Oracle database has yet been created within this reference architecture, the default value of 150 *PROCESSES* is used.





Finally, add the current `FS.FILE-MAX` value with the new value found from multiplying `512*PROCESSES` to attain the new `FS.FILE-MAX` value.

```
# echo "32768 + 76800" | bc
109568
```

While the value of the `FS.FILE-MAX` parameter varies upon your environment, this reference architecture sets the value at 6815744. Oracle recommends a value no smaller than 6815744. Due to the calculation in the above example equating to 109568, the minimum Oracle recommended value was used. In order to add `FS.FILE-MAX` to 6815744, modify the `/etc/sysctl.conf` file as follows:

```
fs.file-max = 6815744
```

In order for the changes take effect immediately, run the following command:

```
# sysctl -p
```

**NOTE:** It is recommended to revisit the `FS.FILE-MAX` value if the `PROCESSES` value is increased for the Oracle database instance.

**NOTE:** A full listing of all the kernel parameters modified within the `/etc/sysctl.conf` file can be found at **Appendix G Kernel Parameters**.

### 3.3.12 User Accounts & Groups

Prior to the installation of Oracle Database 11g Release 2 (11.2.0.3), Oracle recommends the creation of a `GRID` user for the Oracle Grid Infrastructure and an `ORACLE` user for the Oracle Database software installed on the system. For the purposes of this reference architecture, the Oracle Database software owner is the user `ORACLE` and the Oracle Grid Infrastructure for a standalone server software owner is the user `GRID`. Each user is designated different groups to handle specific roles based on the software installed. However, the creation of separate users requires that both the `ORACLE` user and the `GRID` user have a common primary group, the Oracle central inventory group (`OINSTALL`).

The following are the recommended system groups created for the installation of the Oracle Database and part of the oracle user.

OSDBA group (`DBA`) – determines OS user accounts with DBA privileges

OSOPER group (`OPER`) – an optional group created to assign limited DBA privileges (`SYSOPER` privilege) to particular OS user accounts

The following are the recommended system groups created for the installation of the Oracle Grid Infrastructure and part of the `GRID` user

OSDBA group (`ASMDBA`) – provides administrative access to Oracle ASM instances

OSASM group (`ASMADMIN`) – provides administrative access for storage files via the `SYSASM` privilege

OSOPER group (`ASMOPER`) – an optional group created to assign limited DBA privileges with regards to ASM to particular OS user accounts

As the root user, create the following user accounts, groups, and group assignments using a consistent UID and GID assignments across your organization:

```
# groupadd --gid 54321 oinstall
# groupadd --gid 54322 dba
# groupadd --gid 54323 asmdba
# groupadd --gid 54324 asmoper
# groupadd --gid 54325 asmadmin
# groupadd --gid 54326 oper

# useradd --uid 54321 --gid oinstall --groups dba,oper,asmdba,asmoper oracle
# passwd oracle

# useradd --uid 54322 --gid oinstall --groups dba,asmadmin,asmdba,asmoper grid
# passwd grid
```

Verify the `GRID` and `ORACLE` user correctly display the appropriate primary and supplementary groups via the commands:

```
# id oracle
uid=54321(oracle) gid=54321(oinstall)
groups=54321(oinstall),54322(dba),54323(asmdba),54324(asmoper),54326(oper)

# id grid
uid=54322(grid) gid=54321(oinstall)
groups=54321(oinstall),54322(dba),54323(asmdba),54324(asmoper),54325(asmadmin)
```

### 3.3.13 Setting Shell Limits for the Grid and Oracle User

Oracle recommends the following settings for the soft and hard limits for the number of open file descriptors (`nfile`), number of processes (`nproc`), and size of the stack segment (`stack`) allowed by each user respectively. The purpose of setting these limits is to prevent a system wide crash that could be caused if an application, such as Oracle, were allowed to exhaust all of the OS resources under an extremely heavy workload.

Create a file labeled `99-grid-oracle-limits.conf` within `/etc/security/limits.d/` as follows:

```
# touch /etc/security/limits.d/99-grid-oracle-limits.conf
```

**NOTE:** The reason that the `/etc/security/limits.conf` file is not directly modified is due to the order in which limit files are read in the system. After reading the `/etc/security/limits.conf` file, files within the `/etc/security/limits.d/` directory are read. If two files contain the same entry, the entry read last takes precedence. For more information visit Red Hat Article: “What order are the limit files in the `limits.d` directory read in?”<sup>6</sup>

---

6 What order are the limits files in the `limits.d` directory read in? - <https://access.redhat.com/site/solutions/199993>



Within the `/etc/security/limits.d/99-grid-oracle-limits.conf` file, add the following soft and hard limits for the `oracle` and `grid` user:

```
oracle soft nproc 2047
oracle hard nproc 16384
oracle soft nofile 1024
oracle hard nofile 65536
oracle soft stack 10240
oracle hard stack 32768
grid soft nproc 2047
grid hard nproc 16384
grid soft nofile 1024
grid hard nofile 65536
grid soft stack 10240
grid hard stack 32768
```

**NOTE:** Modifications made to the `99-grid-oracle-limits.conf` file take effect immediately. However, please ensure that any previously logged in `oracle` or `grid` user sessions (if any) are logged out and logged back in for the changes to take effect.

As the root user, create a shell script labeled `oracle-grid.sh` within `/etc/profile.d/` to create the appropriate `ulimits` for the `oracle` and `grid` user. The contents of the `oracle-grid.sh` script can be seen below.

```
#Setting the appropriate ulimits for oracle and grid user
if [ $USER = "oracle" ]; then
    if [ $SHELL = "/bin/ksh" ]; then
        ulimit -u 16384
        ulimit -n 65536
    else
        ulimit -u 16384 -n 65536
    fi
fi

if [ $USER = "grid" ]; then
    if [ $SHELL = "/bin/ksh" ]; then
        ulimit -u 16384
        ulimit -n 65536
    else
        ulimit -u 16384 -n 65536
    fi
fi
```

**NOTE:** While the `ulimit` values can be set directly within the `/etc/profile` file, it is recommended to create a custom shell script within `/etc/profile.d` instead. The `oracle-grid.sh` script can be downloaded from the **Appendix K Configuration Files**

As `oracle` and `grid` user, verify the `ULIMIT` values by running the following command:

```
# ulimit -a
core file size          (blocks, -c) 0
data seg size          (kbytes, -d) unlimited
scheduling priority    (-e) 0
```

```

file size          (blocks, -f) unlimited
pending signals    (-i) 385878
max locked memory  (kbytes, -l) 14854144
max memory size    (kbytes, -m) unlimited
open files         (-n) 65536
pipe size          (512 bytes, -p) 8
POSIX message queues (bytes, -q) 819200
real-time priority (-r) 0
stack size         (kbytes, -s) 10240
cpu time           (seconds, -t) unlimited
max user processes (-u) 16384
virtual memory     (kbytes, -v) unlimited
file locks         (-x) unlimited

```

## 3.4 Storage Configuration

The following storage configuration section describes the best practices for setting up device mapper multipath, the use of *udev* rules or Oracle ASMLib for ASM disk management, and the use of the *tuned* package for optimal performance.

### 3.4.1 Setting up DM-Multipath

*Device mapper multipath* provides the ability to aggregate multiple I/O paths to a newly created device mapper path to achieve high availability, I/O load balancing, and persistent naming. The following procedures provide the best practices to installing and configuring *device mapper multipath* devices.

**NOTE:** Ensure Oracle database volumes are accessible via the operating system prior to continuing with the section below.

1. As the root user, install the *device-mapper-multipath* package using the **yum** package manager.

```
# yum install device-mapper-multipath
```

2. Copy the *multipath.conf* file found within */usr/share/doc/device-mapper-multipath-0.4.9/* to */etc/*

```
# cp /usr/share/doc/device-mapper-multipath-0.4.9/multipath.conf /etc/
```



3. Capture the scsi id of the local disk(s) on the system.

```
# scsi_id --whitelisted --replace-whitespace --device=/dev/sda
3600508b1001030353434363646301200
```

4. Uncomment and modify the blacklist section within the `/etc/multipath.conf` file to include the `scsi id` of the local disk on the system. Once complete, save the changes made to the `multipath.conf` file.

```
blacklist {
    wwid 3600508b1001030353434363646301200
    devnode "^(ram|raw|loop|fd|md|dm-|sr|scd|st)[0-9]*"
    devnode "^hd[a-z]"
}
```

5. Start the `multipath` daemon.

```
# service multipathd start
Starting multipathd daemon: [ OK ]
```

6. Enable the `multipath` daemon to ensure it is started upon boot time.

```
# chkconfig multipathd on
```

7. Identify the `dm-` device, `size`, and `WWID` of each `device mapper` volume for Oracle data disks and recovery disks. In this example, volume `mpathb` is identified via the following command:

```
# multipath -ll
```

```
multipath alias name      world wide identifier (WWID)  dm- device
size → | mpathb (3600c0ff000d7e7a89e85ac5101000000) dm-10 HP,MSA2324fc
      | size=186G features='1 queue_if_no_path' hwhandler='0' wp=rw
      | +- policy='round-robin 0' prio=130 status=active
      | | - 3:0:0:3 sdd  8:48  active ready running
      | | - 3:0:1:3 sdh  8:112 active ready running
      | | - 4:0:0:3 sdt  65:48 active ready running
      | | - 4:0:1:3 sdx  65:112 active ready running
      | +- policy='round-robin 0' prio=10 status=enabled
      | | - 3:0:2:3 sdl  8:176 active ready running
      | | - 3:0:3:3 sdp  8:240 active ready running
      | | - 4:0:2:3 sdab 65:176 active ready running
      | | - 4:0:3:3 sdaf 65:240 active ready running
```

**Figure 3.4.1.1: Multipath Device (mpathb)**

**Figure 3.4.1.1: Multipath Device (mpathb)** properly identifies the current multipath alias name, size, `WWID`, and `dm` device. This information is required for the application of a custom alias to each volume as shown in step 9.

8. Uncomment the defaults section found within the `/etc/multipath.conf` file.

```
defaults {
    udev_dir                /dev
    polling_interval        10
    path_selector            "round-robin 0"
    path_grouping_policy    multibus
    getuid_callout          "/lib/udev/scsi_id --whitelisted"
    --device="/dev/%n"
    prio                    alua
    path_checker            readsector0
    rr_min_io               100
    max_fds                 8192
    rr_weight               priorities
    failback                immediate
    no_path_retry           fail
    user_friendly_names     yes
}
```

9. Uncomment the multipath section found within the `/etc/multipath.conf` file and create an alias for each *device mapper* volume in order to enable persistent naming of those volumes. Once complete, save the changes made to the `multipath.conf` file. The output should resemble the example below. For reference, refer the Oracle data volumes created for this reference architecture as seen on **Table 2.4.3: Oracle Data File Sizes for Reference Architecture**.

```
multipaths {
    multipath {
        wwid                3600c0ff000d7e7a899d8515101000000
        alias                db1
    }
    multipath {
        wwid                3600c0ff000dabfe5a7d8515101000000
        alias                db2
    }
    multipath {
        wwid                3600c0ff000d7e7a8dbd8515101000000
        alias                fra
    }
    multipath {
        wwid                3600c0ff000dabfe5f4d8515101000000
        alias                redo
    }
}
```



10. Restart the *device mapper multipath* daemon.

```
# service multipathd restart
ok
Stopping multipathd daemon: [ OK ]
Starting multipathd daemon: [ OK ]
```

11. Verify the *device mapper* paths and aliases are displayed properly. Below is an example of one *device mapper* device labeled *fra*.

```
# multipath -ll
fra (3600c0ff000d7e7a89e85ac5101000000) dm-10 HP,MSA2324fc
size=186G features='1 queue_if_no_path' hwhandler='0' wp=rw
|-+- policy='round-robin 0' prio=130 status=active
|  |- 3:0:0:3 sdd 8:48 active ready running
|  |- 3:0:1:3 sdh 8:112 active ready running
|  |- 4:0:0:3 sdt 65:48 active ready running
|  `-- 4:0:1:3 sdx 65:112 active ready running
`-+- policy='round-robin 0' prio=10 status=enabled
   |- 3:0:2:3 sdl 8:176 active ready running
   |- 3:0:3:3 sdp 8:240 active ready running
   |- 4:0:2:3 sdab 65:176 active ready running
   `-- 4:0:3:3 sdaf 65:240 active ready running
```

### 3.4.2 Partitioning Device Mapper Shared Disks

Partitioning of the *device mapper* shared disks is only required when using Oracle *ASMLib*. For the simplification of ensuring to meet all requirements, this reference architecture creates a partition for each device mapper volume. For each device mapper volume, create a partition using *parted*. An example is shown below.

```
# parted /dev/mapper/db1 mklabel gpt mkpart primary "1 -1"
Information: You may need to update /etc/fstab.
```

Once the partition is created, a newly created device mapper device is created as *db1p1*.

```
# ls -l /dev/mapper/db1p1
lrwxrwxrwx. 1 root root 8 Apr 16 15:15 /dev/mapper/db1p1 -> ../dm-11
```

**NOTE:** A newly created partition requires the alias name followed by *p1* such as *db1p1* seen above. If *p1* is missing, please run the following command to add the partition mappings to the device mapper disks.

```
# kpartx -a /dev/mapper/db1
```



### 3.4.3 Configuring Oracle ASM Disks

The configuration of Oracle ASM requires the use of either *udev* rules or Oracle's *ASMLib*. It is important to note that Oracle's *ASMLib* is not a requirement for the use of Oracle ASM disks. The reasoning behind providing an Oracle *ASMLib* alternative is due to *udev* rules not requiring additional kernel modules, unlike Oracle *ASMLib* that requires a kernel module labeled `kmod-oracleasm` and proprietary user space utilities to properly function. This section focuses on the implementation best practices of using Red Hat's native *udev* rules to setup the appropriate permissions for each device mapper disk, as well as, the best practices for Oracle's *ASMLib*. This reference architecture documents both methods of implementation, however, only one method can be applied for a given solution.

#### 3.4.3.1 Oracle ASMLib Alternative: Configuring Udev Rules

**NOTE:** If following the steps in this section, please ignore **Section 3.4.3.2 Configuring Oracle ASMLib**

The configuration of Oracle ASM requires the use of either *udev* rules or Oracle's *ASMLib*. This section, focuses on the best practices of using Red Hat's native *udev* rules to setup the appropriate permissions for each device mapper disk.

1. As the root user, identify the *Device Mapper Universally Unique Identifier (DM\_UUID)* for each *device mapper* volume. The example below shows the *DM\_UUID* for the partitions of the volumes labeled db1,db2,fra, and redo.

```
# for i in db1p1 db2p1 fra1 redop1; do printf "%s %s\n" "$i" "$(udevadm
info --query=all --name=/dev/mapper/$i | grep -i dm_uuid)"; done
db1p1 E: DM_UUID=part1-mpath-3600c0ff000d7e7a899d8515101000000
db2p1 E: DM_UUID=part1-mpath-3600c0ff000dabfe5a7d8515101000000
fra1 E: DM_UUID=part1-mpath-3600c0ff000d7e7a8dbd8515101000000
redop1 E: DM_UUID=part1-mpath-3600c0ff000dabfe5f4d8515101000000
```

2. Create a file labeled *99-oracle-asmdevices.rules* within */etc/udev/rules.d/*
3. Within *99-oracle-asmdevices.rules* file, create rules for each device similar to the example below:

```
KERNEL=="dm- *", ENV{DM_UUID}=="part1-mpath-
3600c0ff000dabfe5f4d8515101000000", OWNER="grid", GROUP="asmadmin", MODE="06
60"
```

To understand the rule above, it can be read as follows:

If any *dm- device* matches the *DM\_UUID* of *part1-mpath-3600c0ff000dabfe5f4d8515101000000*, assign to that *dm- device* to be owned by the *grid* user and part of the *asmadmin* group with the permission mode set to 0660.

4. Save the file labeled *99-oracle-asmdevices.rules*





5. Locate the *dm-* device for each Oracle related partition. An example to find the *dm-* device for each partition is to run the following command:

```
# for i in db1p1 db2p1 frap1 redop1; do printf "%s %s\n" "$i" "$(ls
-l1 /dev/mapper/$i)"; done
db1p1 lrwxrwxrwx. 1 root root 8 May 20 20:39 /dev/mapper/db1p1 -> ../dm-11
db2p1 lrwxrwxrwx. 1 root root 8 May 20 20:39 /dev/mapper/db1p1 -> ../dm-12
frap1 lrwxrwxrwx. 1 root root 8 May 20 20:39 /dev/mapper/db1p1 -> ../dm-13
redop1 lrwxrwxrwx. 1 root root 8 May 20 20:39 /dev/mapper/db1p1 -> ../dm-14
```

6. Apply and test the rules created within the *99-oracle-asmdevices.rules* by running a *udevadm test* on each device.

```
# udevadm test /sys/block/dm-11
[ ... Output Abbreviated ... ]
udevadm_test: DM_NAME=db1p1
udevadm_test: DM_UUID=part1-mpath-3600c0ff000d7e7a86485ac5101000000
udevadm_test: DM_SUSPENDED=0
udevadm_test: DEVLINKS=/dev/mapper/db1p1 /dev/disk/by-id/dm-name-db1p1
/dev/disk/by-id/dm-uuid-part1-mpath-3600c0ff000d7e7a86485ac5101000000
/dev/block/253:11
udevadm_test: ID_FS_TYPE=oracleasm
```

7. Confirm the device has the desired permissions

```
# ls -lh /dev/dm-11
brw-rw----. 1 grid asmadmin 253, 11 Jun 6 20:59 /dev/dm-11
```

**NOTE:** For simplicity, this *99-oracle-asmdevices.rules* file is included in **Appendix I 99-oracle-asmdevices.rules**

### 3.4.3.2 Configuring Oracle ASMLib

**NOTE:** If **Section 3.4.3.1 Oracle ASMLib Alternative: Configuring Udev Rules** has been configured, ignore this section and continue to **Section 3.4.4 Optimizing Database Storage using Automatic System Tuning**

In order to configure Oracle ASMLib the following components are required: **kmod-oracleasm**, **oracleasm-support**, and **oracleasm-lib**

The *ASMLib* kernel module package (**kmod-oracleasm**) is provided for Red Hat customers via the Supplementary Channel on Red Hat Network (RHN). In order to properly install and configure ASMLib the following procedures must be followed.

As the root user,

1. Enable the Red Hat Enterprise Linux 6 Supplementary repository on RHN<sup>7</sup>.
2. Download the ASMLib library package (**oracleasm-lib**)

```
# wget http://download.oracle.com/otn\_software/asmlib/oracleasm-lib-2.0.4-1.el6.x86\_64.rpm
```

<sup>7</sup> Enabling the Supplementary Repository Knowledge Base Article, <https://access.redhat.com/knowledge/articles/58637>

3. Download the ASMLib utilities package (**oracleasm-support**)

```
# wget http://public-yum.oracle.com/repo/OracleLinux/OL6/latest/x86\_64/oracleasm-support-2.1.8-1.el6.x86\_64.rpm
```

4. Install the ASMLib kernel module package (**kmod-oracleasm**) using the following command:

```
# yum install kmod-oracleasm
```

5. Install the ASMLib library package (**oracleasm-lib**) using the following command:

```
# yum install oracleasm-lib-2.0.4-1.el6.x86_64.rpm
```

6. Install the ASMLib utilities package (**oracleasm-support**) using the following command:

```
# yum install oracleasm-support-2.1.8-1.el6.x86_64.rpm
```

7. Configure ASMLib using the following command:

```
# /usr/sbin/oracleasm configure -i  
Configuring the Oracle ASM library driver.
```

This will configure the on-boot properties of the Oracle ASM library driver. The following questions will determine whether the driver is loaded on boot and what permissions it will have. The current values will be shown in brackets ('[]'). Hitting <ENTER> without typing an answer will keep that current value. Ctrl-C will abort.

```
Default user to own the driver interface []: grid  
Default group to own the driver interface []: asmadmin  
Start Oracle ASM library driver on boot (y/n) [ n ]: y  
Scan for Oracle ASM disks on boot (y/n) [y]: y  
Writing Oracle ASM library driver configuration: done
```

8. Within `/etc/sysconfig/oracleasm`, set the **ORACLEASM\_SCANORDER** and **ORACLEASM\_SCANEXCLUDE** parameters as follows:

```
# ORACLEASM_SCANORDER: Matching patterns to order disk scanning  
ORACLEASM_SCANORDER="dm"  
  
# ORACLEASM_SCANEXCLUDE: Matching patterns to exclude disks from scan  
ORACLEASM_SCANEXCLUDE="sda"
```

**NOTE:** The **ORACLEASM\_SCANORDER** set to `dm` ensures that when oracleasm scans disks, it is appropriately scanning devices known by the kernel. The **ORACLEASM\_SCANEXCLUDE** set to `sda` is ensuring that local disk `sda` is to be ignored by ASMLib.



9. Prior to creating disks with oracleasm, ensure the *SELinux* policy files version **3.7.19-211** is downloaded from **Appendix K Configuration Files** . This ensure that oracleasm properly runs with *SELinux* enabled and avoids any *SELinux* errors<sup>8</sup>. Enable the *SELinux* policy and modules as follows:

- Download a copy of the **selinux-policy-3.7.19-211.el6.noarch.rpm** and **selinux-policy-targeted-3.7.19-211.el6.noarch.rpm** from **Appendix K**
- Update the selinux-policy via the following commands:

```
# rpm -Uvh selinux-policy-3.7.19-211.el6.noarch.rpm selinux-policy-targeted-3.7.19-211.el6.noarch.rpm
Preparing... ##### [100%]
1:selinux-policy ##### [ 50%]
2:selinux-policytargeted##### [100%]
```

<sup>8</sup> oracleasm createdisk fails with *Selinux* enabled [ID 1430947.1]

10. Run the following `oracleasm` command to ensure that `oracleasm` is enabled.

```
# /etc/init.d/oracleasm enable
Writing Oracle ASM library driver configuration: done
Initializing the Oracle ASMLib driver:           [ OK ]
Scanning the system for Oracle ASMLib disks:    [ OK ]
```

11. Run the following `oracleasm` command to create and label all Oracle related volumes as an ASM disk. The example below creates an ASM disk labeled `DATA1` for the following `/dev/mapper/db1p1` partition.

```
# /usr/sbin/oracleasm createdisk DATA1 /dev/mapper/db1p1
Writing disk header: done
Instantiating disk: done
```

**NOTE:** It is highly recommended to have all Oracle related disks to be included within Oracle ASM.

12. Verify all the Oracle ASM disks created are listed.

```
# /usr/sbin/oracleasm listdisks
DATA1
DATA2
FRA1
RED01
```

13. If no disks are listed or if any disks are missing, run the following command to rescan the ASM disks.

```
# /usr/sbin/oracleasm scandisks
Reloading disk partitions: done
Cleaning any stale ASM disks...
Scanning system for ASM disks...
```

**NOTE:** If the issue persists after a rescan of the Oracle ASM disks, a reboot of the system might be required via the command:

```
# shutdown -r now
```



## 3.4.4 Optimizing Database Storage using Automatic System Tuning

The tuned package in Red Hat Enterprise Linux 6 is recommended for automatically tuning the system for common workloads via the use of profiles. Each profile is tailored for different workload scenarios such as: enterprise storage, power savings, and high network throughput. It is recommended to create a custom profile with the same settings as the default enterprise storage profile but that disables Transparent HugePages (THP) for Oracle databases workload environments. For more information on why THP is disabled, see **Section 4.1.5 Enabling HugePages**. **Table 3.4.4.1: Profile Comparison** provides details of the enterprise-storage profile attributes that are adjusted versus the defaults found within the Red Hat Enterprise Linux 6 distribution.

Tuned Parameters	default	enterprise-storage	enterprise-storage-no-thp
I/O Elevator	CFQ	deadline	deadline
CPU governor	OnDemand	performance	performance
kernel.sched_min_granularity_ns	4ms	10ms	10ms
kernel.sched_wake_up_granularity_ns	4ms	15ms	15ms
Disk read-ahead	1x	4x	4x
vm.dirty_ratio	20%	40% <sup>9</sup>	40% <sup>9</sup>
File-system barrier	on	off	off
Transparent HugePages	on	on	off

**Table 3.4.4.1: Profile Comparison**

The following procedures provide the steps that are required to create, install, enable, and select the **enterprise-storage-no-thp** profile.

1. Install the tuned package via the yum package manager.

```
# yum install tuned
```

2. Enable **tuned** to ensure it is started upon boot time.

```
# chkconfig tuned on
```

3. Start the **tuned** service

```
# service tuned start
```

<sup>9</sup> The vm.dirty\_ratio value explicitly set within the `/etc/sysctl.conf` file has precedence over values set by tuned.

4. Copy the existing enterprise-storage profile into a new directory called enterprise-storage-no-thp via the following commands:

```
# cd /etc/tune-profiles/  
# cp -r enterprise-storage enterprise-storage-no-thp
```

5. Disable Transparent HugePages in the new profile via the following command:

```
# sed -ie 's,set_transparent_hugepages always,set_transparent_hugepages never', /etc/tune-profiles/enterprise-storage-no-thp/ktune.sh
```

6. Verify the change was properly set via the following command:

```
# grep set_transparent_hugepages /etc/tune-profiles/enterprise-storage-no-thp/ktune.sh  
set_transparent_hugepages never
```

7. Activate the newly created enterprise-storage-no-thp profile:

```
# tuned-adm profile enterprise-storage-no-thp
```

8. Verify that THP is now disabled via the following command:

```
# cat /sys/kernel/mm/redhat_transparent_hugepage/enabled  
always [never]
```

For simplicity, the enterprise-storage-no-thp profile is included in **Appendix K Configuration Files**

**NOTE:** If at any point in time a revert to the original settings are required, the following command can be run:

```
# service tuned stop
```

To make the change to revert to the original settings permanent across reboots, run the following command:

```
# chkconfig tuned off
```



# 4 Oracle 11gR2 Configuration

## 4.1.1 Installing Oracle Grid Infrastructure (Required for ASM)

The installation of the Oracle Grid Infrastructure for Oracle Database 11g Release 2 (11.2.0.3) is required for the use of Oracle ASM. Prior to the installation of the Oracle Grid Infrastructure, ensure the following prerequisites from the following sections have been met:

- **Reference Architecture Environment**
- **Reference Architecture Configuration Details**

**NOTE:** The reference architecture uses the `/u01/app/grid` as the *grid* base. The owner is set to *grid* and the group is set to *oinstall*. Run the following commands to create the *grid* base directory and set the appropriate permissions:

As the root user,

```
# mkdir --parents /u01/app/grid
# chown --recursive grid.oinstall /u01/
```

1. Download the Oracle Grid Infrastructure software<sup>10</sup> from the My Oracle Support site.
2. As the *grid* user, create a temporary directory within `/u01/app/grid/grid-software` to store the Oracle Grid Software gunzip file, move the Oracle Grid Software gunzip file to the `/u01/app/grid/grid-software` location, ensure the Oracle Grid Software gunzip has the proper permissions and unpack its contents.

As the *grid* user,

```
# mkdir /u01/app/grid/grid-software
# mv p10404530_112030_Linux-x86-64_3of7.zip /u01/app/grid/grid-software
```

As the root user,

```
# chown grid.oinstall p10404530_112030_Linux-x86-64_3of7.zip
```

As the *grid* user,

```
# cd /u01/app/grid/grid-software
# unzip p10404530_112030_Linux-x86-64_3of7.zip
```

3. As the *grid* user, locate the Oracle Grid Infrastructure software and modify the file labeled `cvu_config` to ensure the Oracle Universal Installer (OUI) performs the correct prerequisite checks for Red Hat Enterprise Linux 6.
  - Edit the `cvu_config` file as follows:

```
# sed -i 's/CV_ASSUME_DISTID=0EL4/CV_ASSUME_DISTID=0EL6/'
/u01/app/grid/grid-software/grid/stage/cvu/cv/admin/cvu_config
```

---

<sup>10</sup> Patch 10404530: 11.2.0.3.0 PATCH SET FOR ORACLE DATABASE SERVER, via <http://support.oracle.com>

4. Verify the change with the following **grep** command:

```
# grep CV_ASSUME_DISTID=OEL6 /u01/app/grid/grid-  
software/grid/stage/cvu/admin/cvu_config  
CV_ASSUME_DISTID=OEL6
```

5. As the *grid* user, start the OUI via the command:

```
# /u01/app/grid/grid-software/grid/runInstaller
```

**NOTE:** Ensure to **SSH** with the **-Y** option as the *grid* user from the client server, otherwise the following error will occur.

```
# /u01/app/grid/grid-software/grid/runInstaller  
Starting Oracle Universal Installer...  
  
Checking Temp space: must be greater than 120 MB.   Actual 3690 MB  
Passed  
Checking swap space: must be greater than 150 MB.   Actual 20479 MB  
Passed  
Checking monitor: must be configured to display at least 256 colors  
>>> Could not execute auto check for display colors using command  
/usr/bin/xdpyinfo. Check if the DISPLAY variable is set.   Failed <<<<  
  
Some requirement checks failed. You must fulfill these requirements  
before continuing with the installation,  
  
Continue? (y/n) [n] n
```

6. Within the Download Software Updates window, select the option to either enter the My Oracle Support credentials to **download latest software updates** or select **Skip software updates**. This reference architecture selected **Skip software updates** and click **Next**.
7. Within the Installation Option window, select **Configure Oracle Grid Infrastructure for a Standalone Server** and click **Next**.
8. Within the Product Languages window, select the appropriate language, and click **Next**.
9. Within the Create ASM Disk Group window, provide the following:
  - a Disk Group Name, i.e. *DATA*
  - Redundancy Level
    - *EXTERNAL* – redundancy provided by the storage system RAID, and not by Oracle ASM.
    - *NORMAL* – provides two-way mirroring by Oracle ASM, thus provided two copies of every data extent.
    - *HIGH* – provides three-way mirroring by Oracle ASM thus enduring the loss of two ASM disks within different failure groups.
  - Disks to be assigned to the Disk Group, i.e. */dev/mapper/db1p1*, */dev/mapper/db2p1*

**NOTE:** This reference architecture uses *NORMAL REDUNDANCY*.





To display the appropriate candidate disks, click on the **Change Discovery Path** button and enter as the **Disk Discovery Path** one of the following:

- For Device Mapper devices, type:  
`/dev/mapper/*`
- For Oracle ASMLib marked disks, type:  
`/dev/oracleasm/disks/*`

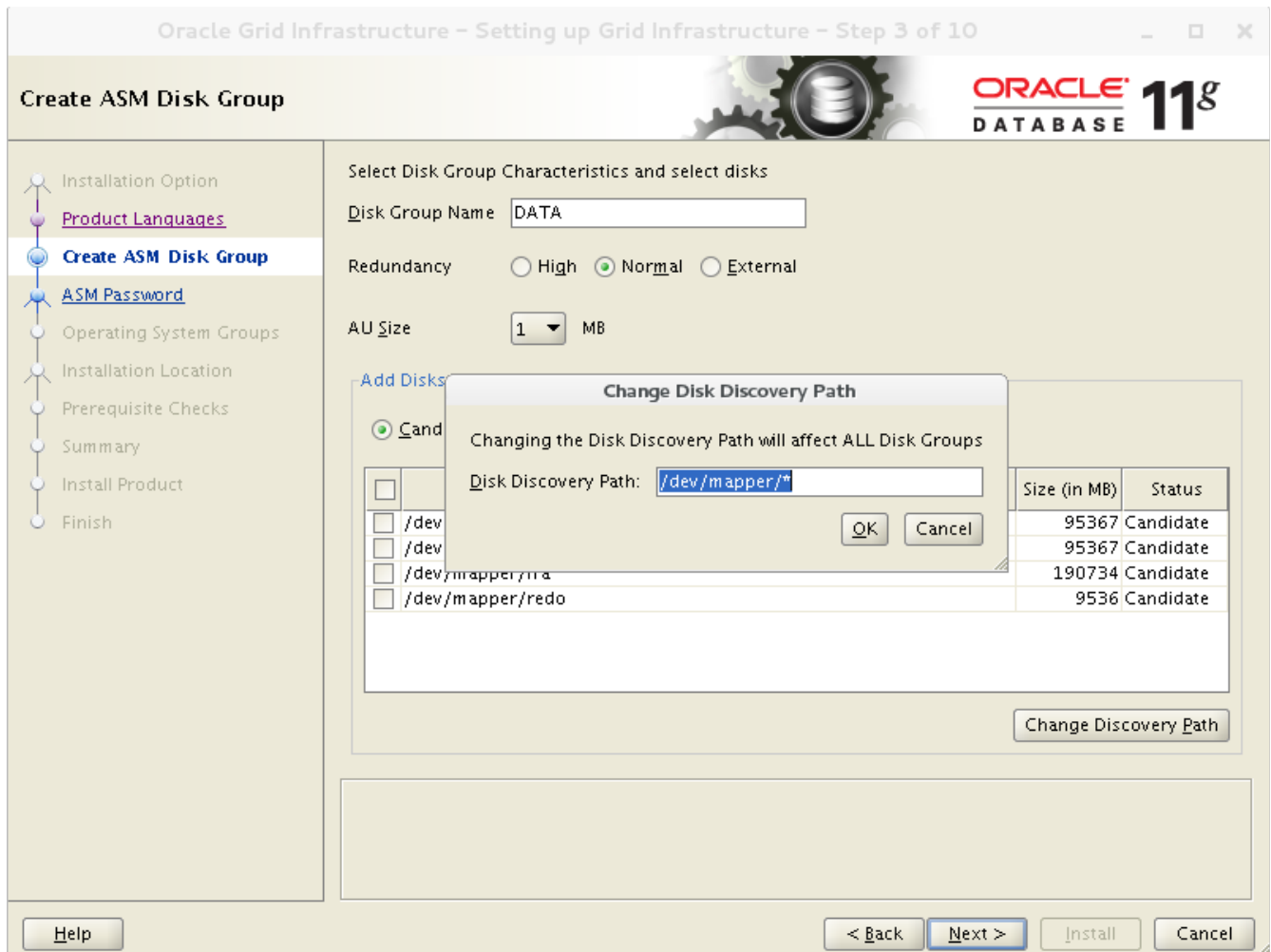

**Figure 4.1.1.1: ASM Disk Group Window**

9. Click **Next** once complete within the Create ASM Disk Group window
10. Within the ASM Password window, specify the password for the SYS and ASMSNMP user accounts.

11. Within the Operating System Groups window, select the appropriate OS groups. The values as created and assigned within this reference architecture are as follows:

- Oracle ASM DBA Group – *ASMDBA*
- Oracle ASM Operator Group – *ASMOPER*
- Oracle ASM Administrator Group – *ASMADMIN*

12. Within the Installation Location window, specify the appropriate Oracle base and software locations. The values set by this reference architecture are as follows:

- *ORACLE BASE* - */u01/app/grid*
- *SOFTWARE LOCATION* - */u01/app/grid/product/11.2.0/grid*

13. Within the Create Inventory window, specify the inventory directory. The values set by this reference architecture are as follows:

- Inventory Directory - */u01/app/oraInventory*

14. Within the Prerequisite Checks window, review the status and ensure there are no errors prior to continuing the installation. For failures with a status set to Fixable, select the **Fix & Check Again** button. The execution of the **Fix & Check Again** button provides a *runfixup.sh* script provided by the OUI. As root, run the *runfixup.sh* and click on the **Check Again** button once the *runfixup.sh* has finished.

15. Within the Summary window, review all the information provided, and select **Install** to start the installation.

16. Once the installation completes, execute the scripts within the 'Execute Configuration scripts' window. As the root user, run the following:

```
# /u01/app/oraInventory/orainstRoot.sh
Changing permissions of /u01/app/oraInventory.
Adding read,write permissions for group.
Removing read,write,execute permissions for world.
Changing groupname of /u01/app/oraInventory to oinstall.
The execution of the script is complete.
# /u01/app/grid/product/11.2.0/grid/root.sh
Performing root user operation for Oracle 11g
```

The following environment variables are set as:

```
ORACLE_OWNER= grid
ORACLE_HOME= /u01/app/grid/product/11.2.0/grid
```

Enter the full pathname of the local bin directory: [/usr/local/bin]:

**/usr/local/bin**

```
Copying dbhome to /usr/local/bin ...
Copying oraenv to /usr/local/bin ...
Copying coraenv to /usr/local/bin ...
```

[ ... Abbreviated Output ... ]

Successfully configured Oracle Grid Infrastructure for a Standalone Server



17. Click **OK** within the Execute Configuration scripts window.
18. Within the Finish window, click **Close**.

## 4.1.2 Installing Oracle 11g R2 Database Software

Prior to the installation of the Oracle Database 11g Release 2 (11.2.0.3), ensure the following prerequisites from the following sections have been met:

- **Reference Architecture Environment**
- **Reference Architecture Configuration Details**

**NOTE:** The reference architecture uses the `/u01/app/oracle` as the Oracle base. The owner is set to `oracle` and the group is set to `oinstall`. Run the following commands to create the `oracle` base directory set the appropriate permissions:

As the root user,

```
# mkdir /u01/app/oracle
# chown --recursive oracle.oinstall /u01/app/oracle
```

1. Download the Oracle Database software<sup>11</sup> from the My Oracle Support site.
2. As the `oracle` user, create a temporary directory within `/u01/app/oracle/oracle-software` to store the Oracle Database Software gunzip files, move the Oracle Database software gunzip files to the `/u01/app/oracle/oracle-software` location, ensure the Oracle Database software gunzip has the proper permissions and unpack its contents.

As the `oracle` user,

```
# mkdir /u01/app/oracle/oracle-software
# mv p10404530_112030_Linux-x86-64_1of7.zip p10404530_112030_Linux-x86-64_2of7.zip /u01/app/oracle/oracle-software/
```

As the `root` user,

```
# chown oracle.oinstall /path/to/p10404530_112030_Linux-x86-64_1of7.zip
# chown oracle.oinstall /path/to/p10404530_112030_Linux-x86-64_2of7.zip
```

As the `oracle` user,

```
# cd /u01/app/oracle/oracle-software
# unzip p10404530_112030_Linux-x86-64_1of7.zip
# unzip p10404530_112030_Linux-x86-64_2of7.zip
```

3. As the `oracle` user, locate the Oracle Database software and modify the file labeled `cvu_config` to ensure the Oracle Universal Installer (OUI) performs the correct prerequisite checks for Red Hat Enterprise Linux 6.
4. Edit the `cvu_config` file as follows:

```
sed -i 's/CV_ASSUME_DISTID=OEL4/CV_ASSUME_DISTID=OEL6/'
/u01/app/oracle/oracle-software/database/stage/cvu/cv/admin/cvu_config
```

<sup>11</sup> Patch 10404530: 11.2.0.3.0 PATCH SET FOR ORACLE DATABASE SERVER, via <http://support.oracle.com>

5. Verify the change with the following **grep** command:

```
# grep CV_ASSUME_DISTID=OEL6 /u01/app/oracle/oracle-  
software/database/stage/cvu/cv/admin/cvu_config  
CV_ASSUME_DISTID=OEL6
```

6. As the *oracle* user, start the OUI via the command:

```
# /u01/app/oracle/oracle-software/database/runInstaller
```

**NOTE:** Ensure to **SSH** with the **-Y** option as the *oracle* user from the client server, otherwise the following error will occur.

```
# /u01/app/oracle/oracle-software/database/runInstaller  
Starting Oracle Universal Installer...  
  
Checking Temp space: must be greater than 120 MB.   Actual 3461 MB  
Passed  
Checking swap space: must be greater than 150 MB.   Actual 20479 MB  
Passed  
X11 connection rejected because of wrong authentication.  
X11 connection rejected because of wrong authentication.  
Checking monitor: must be configured to display at least 256 colors  
>>> Could not execute auto check for display colors using command /  
usr/bin/xdpyinfo. Check if the DISPLAY variable is set.   Failed <<<<  
  
Some requirement checks failed. You must fulfill these requirements  
before continuing with the installation,  
  
Continue? (y/n) [n] n
```

7. Within the Configure Security Updates window, provide the My Oracle Support email address for the latest security issues information, otherwise uncheck the **I wish to receive security updates via My Oracle Support** and click **Next**.
8. Within the Download Software Updates window, provide the My Oracle Support credentials to download the latest security updates, otherwise select the **Skip software updates** radio button. This reference architecture selected **Skip software updates**. Click **Next**.



9. Within the Installation Option window, select **Install database software only** and click **Next**.

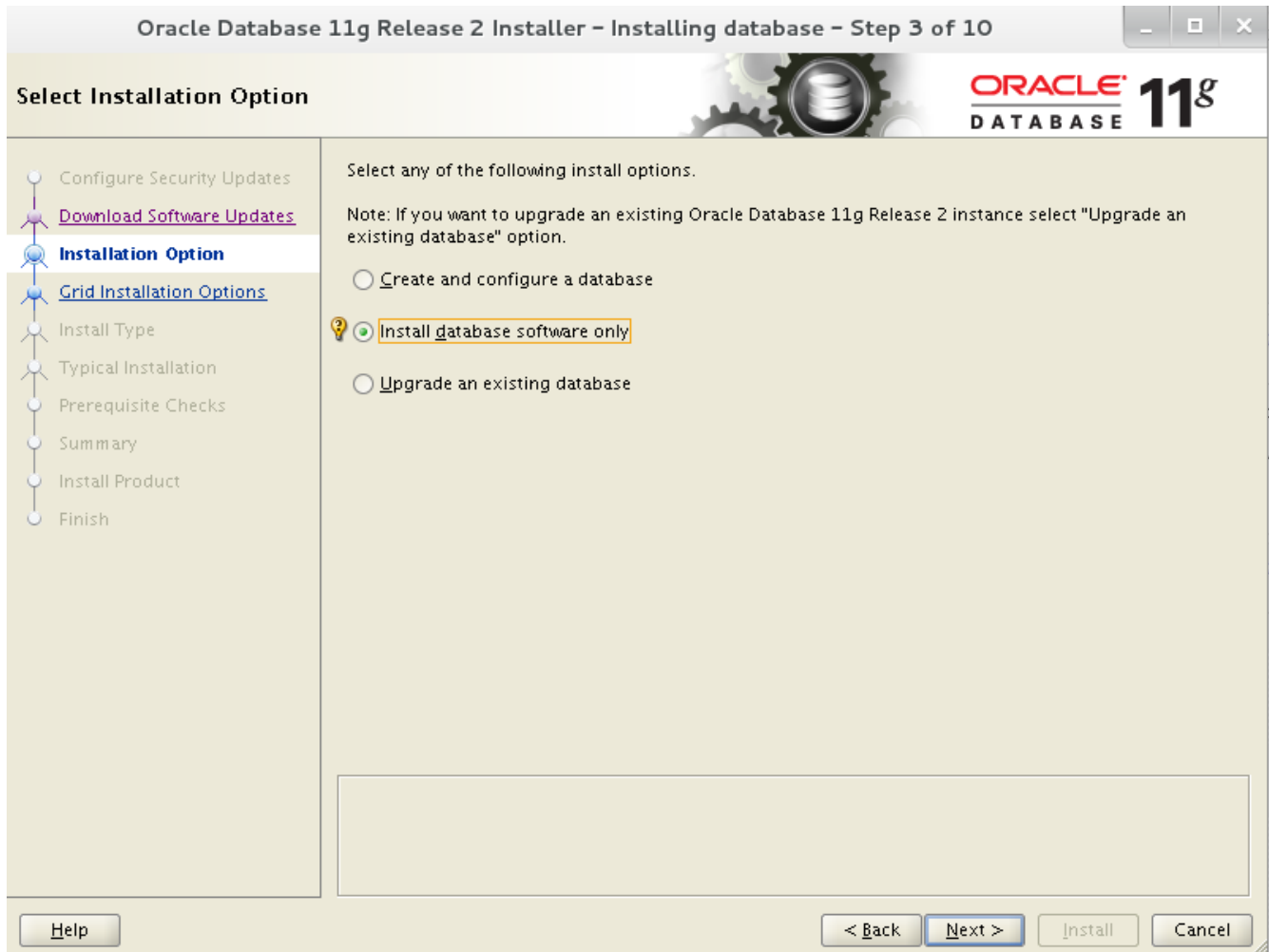

**Figure 4.1.2.1: Installation Option Window**

10. Within the Grid Installation Options, select **Single Instance database installation** as the type of database installation being performed.

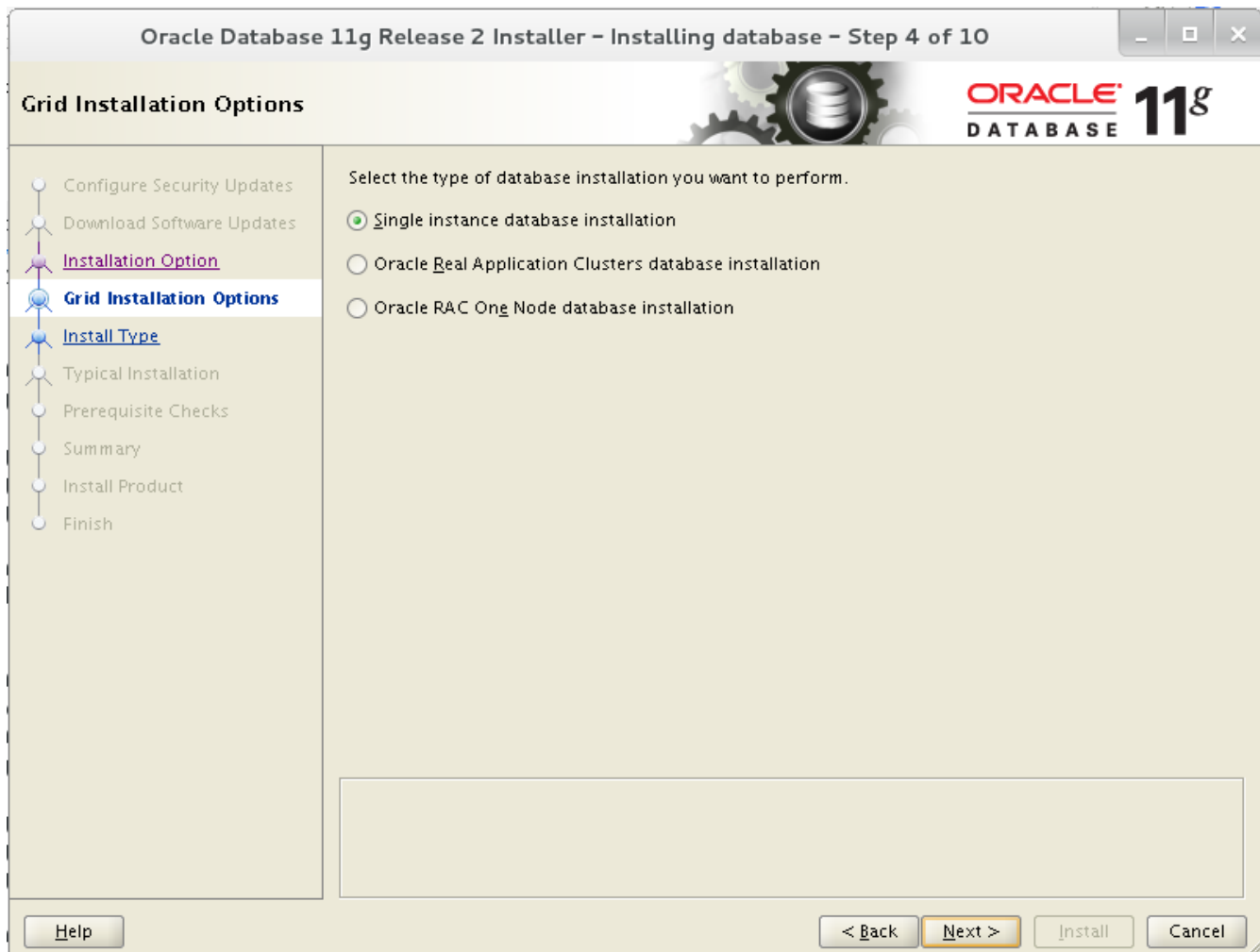

**Figure 4.1.2.2: Grid Installation Options Window**

11. Within the Product Languages window, select the appropriate language for the installation.
12. Within the Database Edition window, select the appropriate database edition and click **Next**. For the purposes of this reference architecture, *Enterprise Edition* is the edition of choice.
13. Within the Installation Location window, select the appropriate Oracle base and software location and click **Next**. For the purposes of this reference architecture, the following are set as:
  - *ORACLE BASE* - /u01/app/oracle
  - *SOFTWARE LOCATION* - /u01/app/oracle/product/11.2.0/dbhome\_1



13. Within the Operating System Groups window, select the appropriate OS groups and click **Next**. For the purposes of this reference architecture, the following are set as:
  - Database Administrator Group – *DBA*
  - Database Operator Group – *OPER*
14. Within the Prerequisite Checks window, review the status and ensure there are no errors prior to continuing the installation. For failures with a status set to Fixable, select the **Fix & Check Again** button. The execution of the **Fix & Check Again** button provides a *runfixup.sh* script provided by the OUI. As root, run the *runfixup.sh* and click on the **Check Again** button once the *runfixup.sh* has finished.
15. Within the Summary window, review all the information provided, and select **Install** to start the installation.
16. Once the installation completes, execute the scripts within the Execute Configuration scripts window. As the root user, run the following:

```
# /u01/app/oracle/product/11.2.0/dbhome_1/root.sh
Performing root user operation for Oracle 11g

The following environment variables are set as:
  ORACLE_OWNER= oracle
  ORACLE_HOME=  /u01/app/oracle/product/11.2.0/dbhome_1

Enter the full pathname of the local bin directory: [/usr/local/bin]:
/usr/local/bin
The contents of "dbhome" have not changed. No need to overwrite.
The contents of "oraenv" have not changed. No need to overwrite.
The contents of "coraenv" have not changed. No need to overwrite.

Entries will be added to the /etc/oratab file as needed by
Database Configuration Assistant when a database is created
Finished running generic part of root script.
Now product-specific root actions will be performed.
Finished product-specific root actions.
```

17. Click **OK** within the Execute Configuration scripts window.
18. Within the Finish window, click **Close**.

**NOTE:** In the example above, */u01/app/oracle/product/11.2.0/dbhome\_1* is the Oracle home directory.

### 4.1.3 Creating ASM Diskgroups via the ASM Configuration Assistant (ASMCA)

Prior to the creation of an Oracle database, create the Fast Recovery Area and Redo Logs Oracle ASM diskgroups via Oracle's ASM Configuration Assistant (ASMCA).

1. As the *grid* user, start *asmca* via the following command:

```
# /u01/app/grid/product/11.2.0/grid/bin/asmca
```

**NOTE:** In the example above, */u01/app/grid/product/11.2.0/grid* is the *grid* home directory.

2. Via the *asmca* application, select the **Disk Groups** tab and click **Create**.

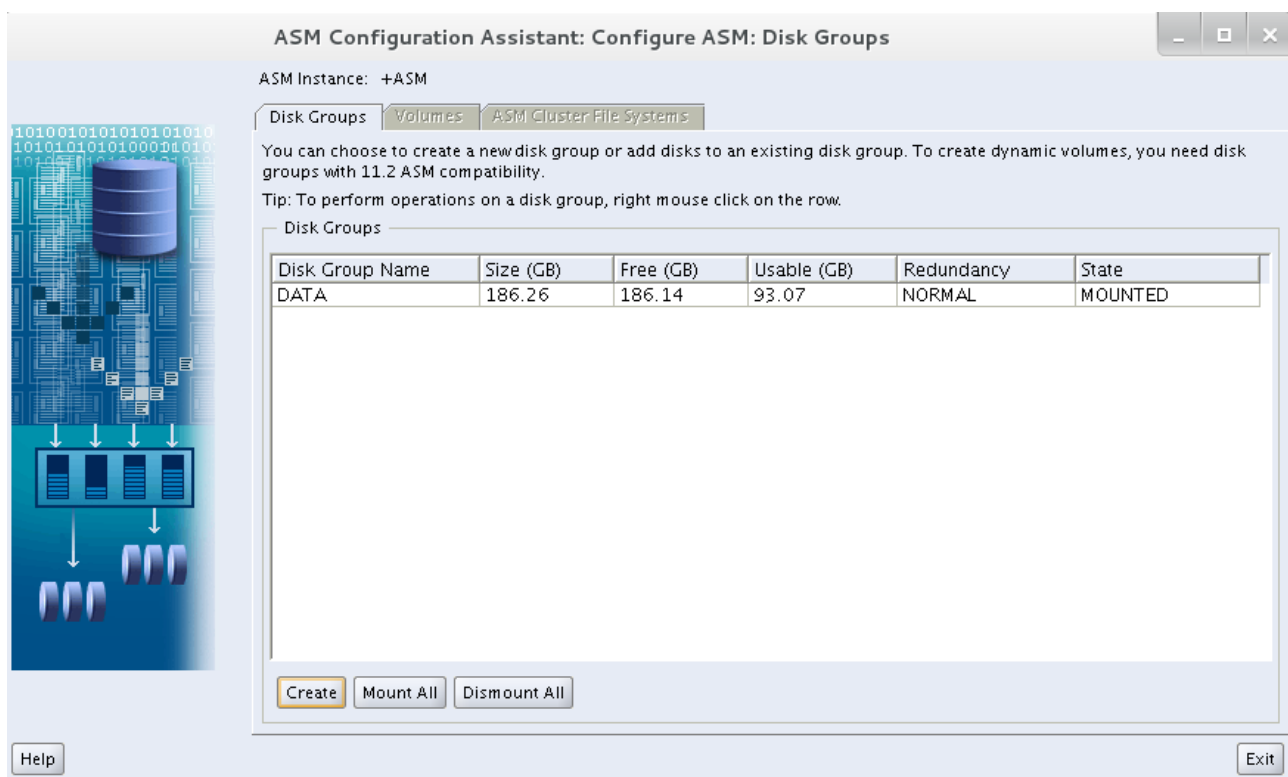

Figure 4.1.3.1: ASMCA DiskGroup Tab





3. Within the Create Disk Group window, provide the following:
  - A name for the disk group, i.e. *FRADG*
  - Redundancy level for the disk group, i.e. *External Redundancy*
  - Selection of the disks to be added to the disk group, i.e. */dev/mapper/frag1*

Create Disk Group

Disk Group Name: FRADG

Redundancy:  High  Normal  External (None)

Select Member Disks:  Show Eligible  Show All

<input type="checkbox"/>	Disk Path	Header Status	Disk Name	Size (MB)	Quorum
<input checked="" type="checkbox"/>	/dev/mapper/frag1	CANDIDATE		190733	<input type="checkbox"/>
<input type="checkbox"/>	/dev/mapper/redop1	CANDIDATE		9535	<input type="checkbox"/>

Disk Discovery Path: /dev/mapper/\*

Show Advanced Options OK Cancel Help

**Figure 4.1.3.2: ASMCA DiskGroup Creation Window**

**NOTE:** To display the appropriate eligible disks, click on the **Change Discovery Path** button and enter as the 'Disk Discovery Path' one of the following:

- For Device Mapper devices, type:  
***/dev/mapper/\****
- For Oracle ASMLib marked disks, type:  
***/dev/oracleasm/disks/\****

Click the **OK** button once the steps above are complete.

4. Repeat steps 2 and 3 to configure both a disk group for the Fast Recovery Area (FRA) and the redo logs.  
**NOTE:** Separation of redo logs into a separate Oracle ASM disk group is optional, but recommended.
5. Once all disk groups are created, click the **Exit** button from the main ASM Configuration Assistant window. Click **yes**, when asked to confirm quitting the application.

## 4.1.4 Creating a Database using Database Configuration Assistant (DBCA)

When creating an Oracle database, the recommended method is the usage of the DBCA utility. The following section describes the step-by-step to create a custom database.

1. As the *oracle* user, run the *dbca* utility via the command:

```
# /u01/app/oracle/product/11.2.0/dbhome_1/bin/dbca
```

**NOTE:** In the example above, */u01/app/oracle/product/11.2.0/dbhome\_1* is the Oracle home directory.

2. Within the Welcome window, click **Next**.
3. Within the Operations window, select **Create a Database** radio button and click **Next**.
4. Within the Database Template window, select **Custom Database** radio button and click **Next**.
5. Within the Database Identification window, set a global database name and Oracle System Identifier (SID), i.e. *oracledb* and click **Next**.
6. Within the Management Options window, configure Enterprise Manager and enable daily disk backup to recovery area (optional), and click **Next**.
7. Within the Database Credentials window, provide the administrative passwords for each username and click **Next**.



8. Within the Database File Locations window, select the appropriate storage type and storage location. For the purposes of this reference architecture the following selections were made:
  - Storage Type – Automatic Storage Management (ASM)
  - Storage Locations – Use Oracle-Managed Files
    - Database Area: +DATA

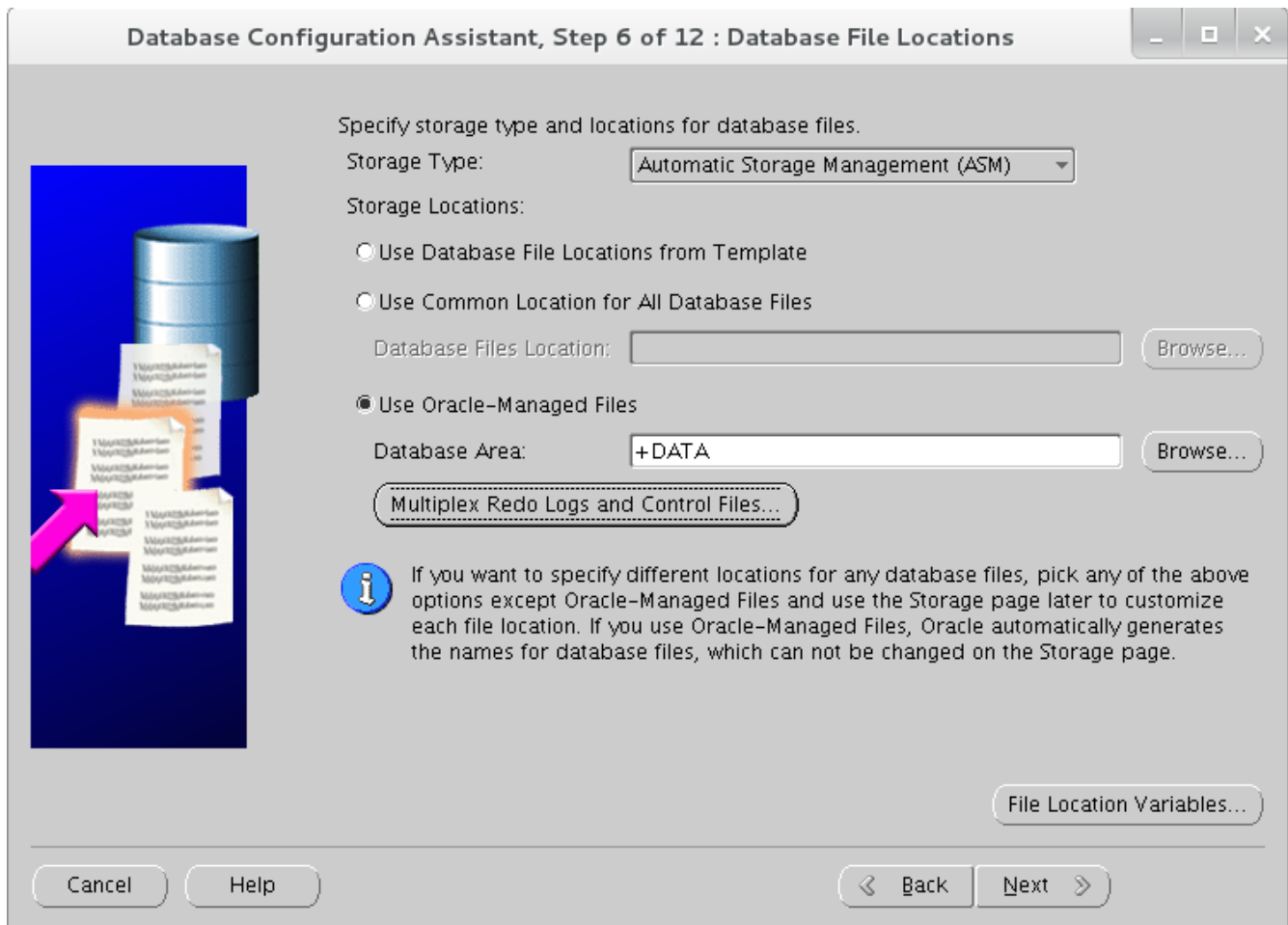

**Figure 4.1.4.1: Database File Locations Window**

9. Select the **Multiplex Redo Logs and Control Files** button and within the Multiplex Redo Logs and Control Files window, add the Redo Logs diskgroup, i.e. +REDODG and click **OK**, then click **Next**.

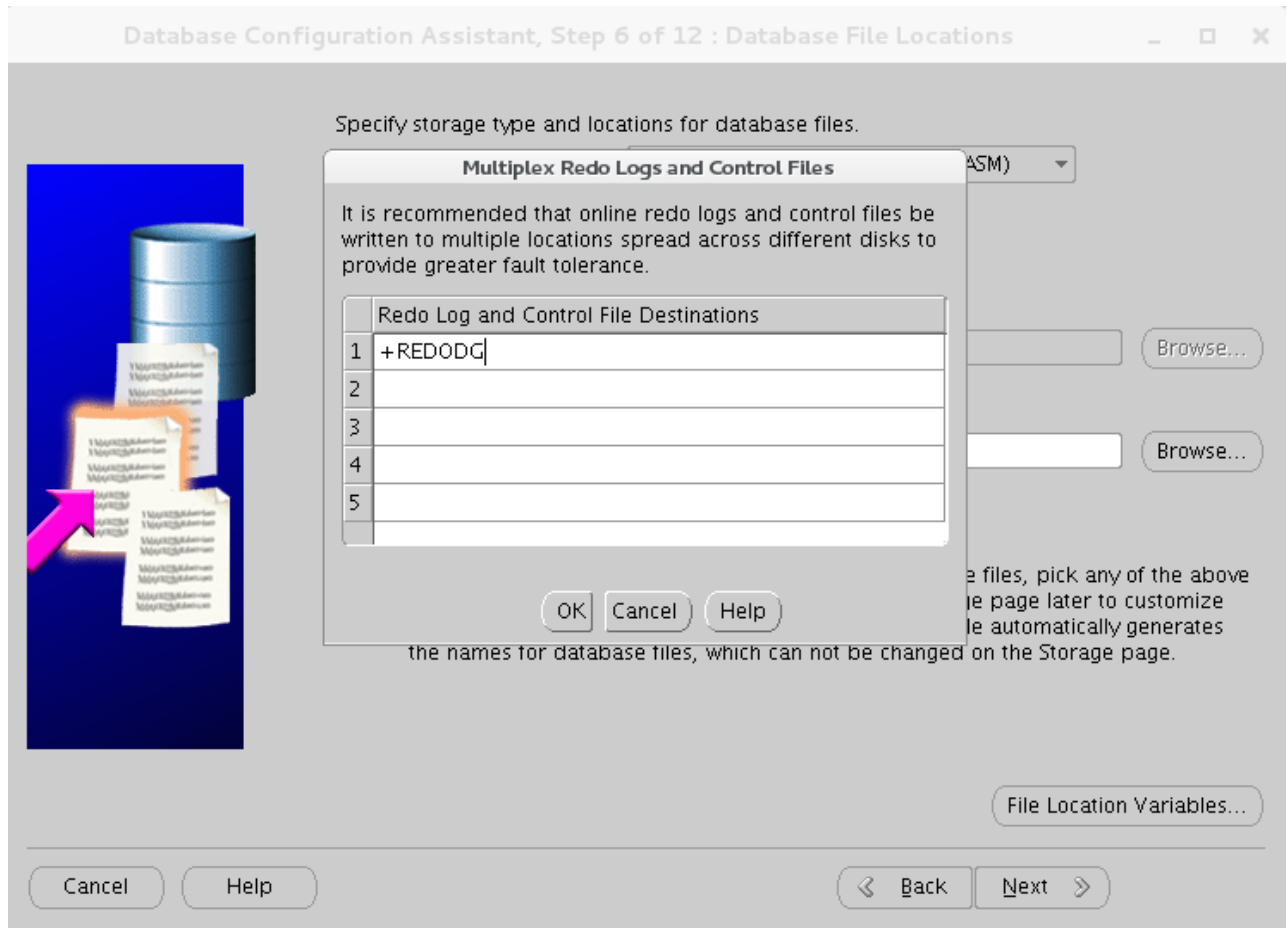

**Figure 4.1.4.2: Multiplex Redo Logs and Control Files Window**

10. Within the ASM Credentials window, specify a *ASMSNMP* password and click **OK**.



11. Within the Recovery Configuration window, select the recovery options appropriate for the database. The selections for this reference architecture enable the Fast Recovery Area (FRA) and Archiving. The FRA location and size as seen below and click **Next**.

- FRA – +FRADG
- FRA Size – 190680 Megabytes (total size of FRA)

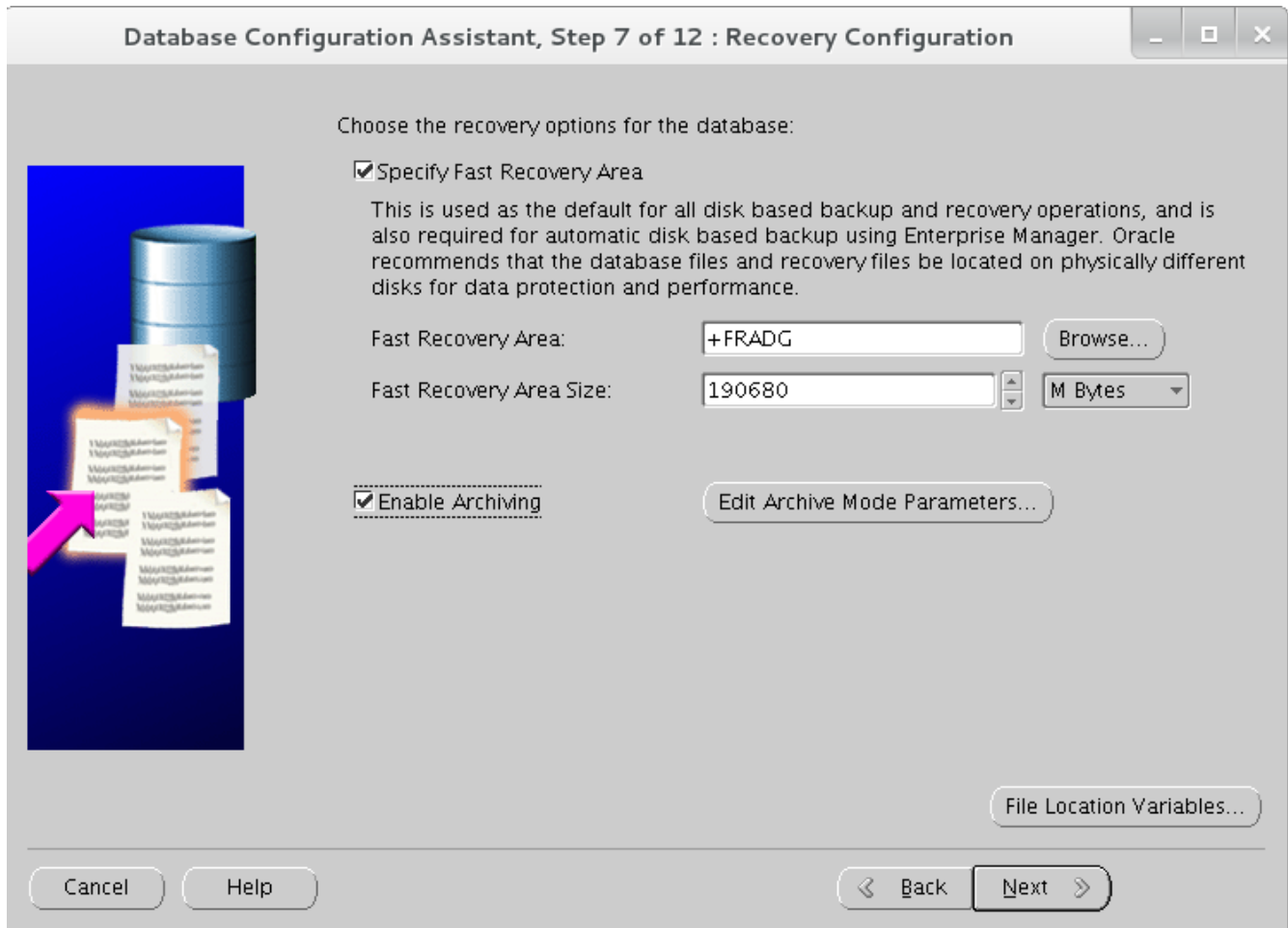

**Figure 4.1.4.3: Recovery Configuration Window**

**NOTE:** It is recommended, to modify the values above based on the database's recovery requirements. For more information, visit My Oracle Support Doc ID [305648.1] – “What is Flash Recovery Area and how to configure it?”.

12. Within the Database Content window, select the components to be configured for the database and click **Next**. The selections for this reference architecture were the default settings.

13. Within the Initialization Parameters window, select **Custom** and enter the appropriate values for the *SGA* and *PGA* size and click **Next**. It is recommended that the Memory Management be set as *Automatic Shared Memory Management*. The values set for the reference architecture with regards to *SGA* and *PGA* are the following:

- SGA – 14475 Megabytes
- PGA – 4825 Megabytes

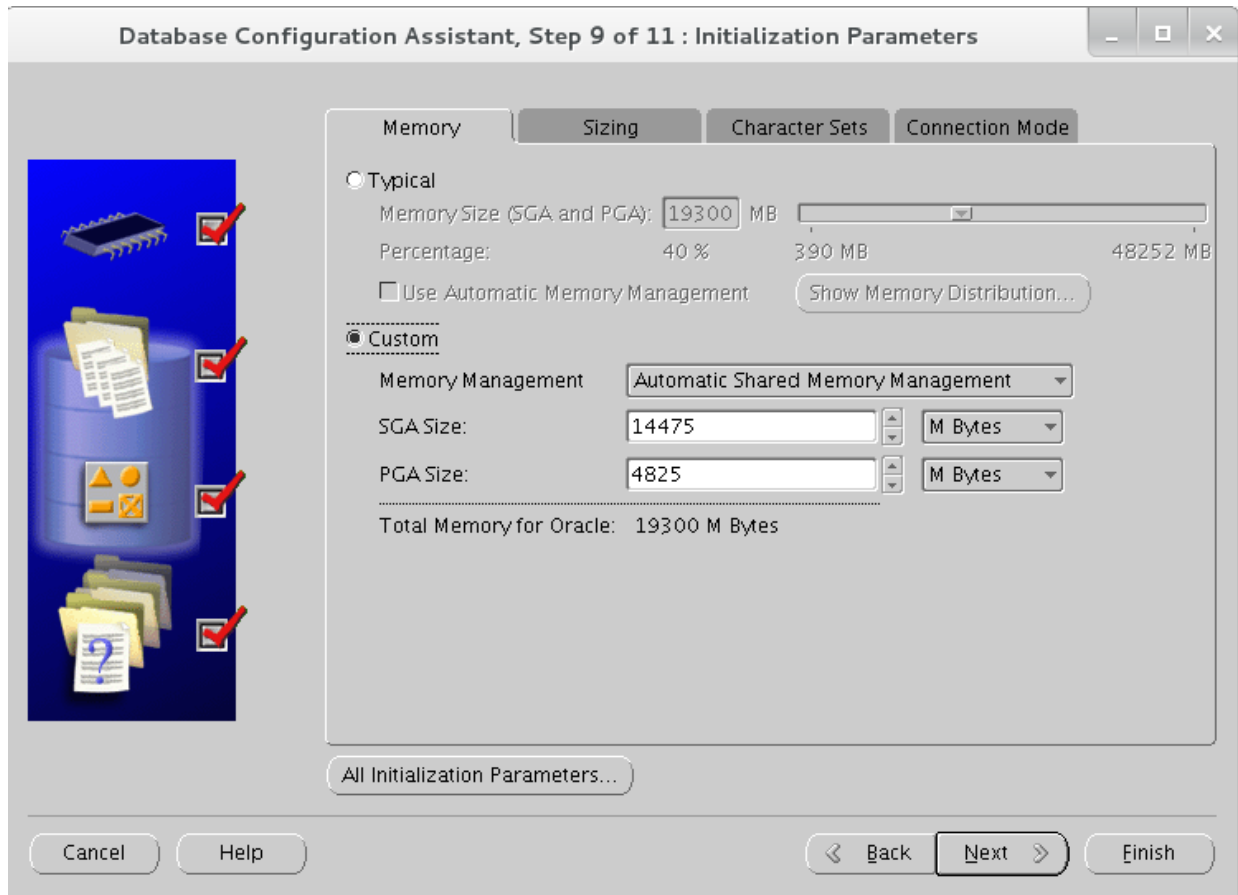

**Figure 4.1.4.4: Initialization Parameters Window**

**NOTE:** It is recommended to modify the values above based on the database's SGA and PGA requirements.

14. Within the Database Storage window, click **Next**.
15. Within the Creation Options window, ensure the **Create Database** box is checked and click **Finish**.
16. Within the Confirmation window, review the database configuration summary, and click **OK** to start the database creation.



## 4.1.5 Enabling HugePages

Red Hat Enterprise Linux 6, by default, uses *transparent huge pages* also known as *anonymous huge pages*. Transparent Huge Pages (THP) are implemented within Red Hat Enterprise Linux 6 to improve memory management by removing many of the difficulties of manually managing huge pages by dynamically allocating huge pages as needed. Unlike static huge pages, no additional configuration is needed to use them. Huge pages can boost application performance by increasing the chance a program will have quick access to a memory page. Unlike traditional huge pages, transparent huge pages can be swapped out (as smaller 4kB pages) when virtual memory clean up is required.

Unfortunately, Oracle Databases do not take advantage of transparent huge pages for interprocess communication. In fact, My Oracle Support [ID 1557478.1]<sup>12</sup> states to disable THP due to unexpected performance issues or delays when THP is found to be enabled. To reap the benefit of huge pages for an Oracle database, it is required to allocate static huge pages and disable THP. Due to the complexity of properly configuring huge pages, it is recommended to copy the bash shell script found within **Appendix E Huge Pages Script** and run the script once the database is up and running. The reasoning behind allocating huge pages once the database is up and running is to provide a proper number of pages to handle the running shared memory segments. The steps are as follows:

1. Copy the bash script found within **Appendix E Huge Pages Script** and save it as *huge\_pages\_settings.sh*
2. As the root user, ensure the *huge\_pages\_settings.sh* is executable by running the following command:

```
# chmod +x huge_pages_settings.sh
```

3. As the root user, execute the *huge\_pages\_settings.sh* script as follows:

```
# ./huge_pages_settings.sh
Recommended setting within the kernel boot command line: hugepages = <value>
Recommended setting within /etc/security/limits.d/99-grid-oracle-limits.conf:
oracle soft memlock <value>
Recommended setting within /etc/security/limits.d/99-grid-oracle-limits.conf:
oracle hard memlock <value>
```

4. Add the number of *hugepages* provided by the *huge\_pages\_settings.sh* script to the kernel boot command line within the */etc/grub.conf* and disable *transparent huge pages* persistently across reboots as follows:

```
title Red Hat Enterprise Linux (2.6.32-358.el6.x86_64)
  root (hd0,0)
  kernel /vmlinuz-2.6.32-358.el6.x86_64 ro root=/dev/mapper/myvg-root
  rd_NO_LUKS LANG=en_US.UTF-8 rd_NO_MD SYSFONT=latarcyrheb-sun16
  crashkernel=auto rd_NO_DM rd_LVM_LV=myvg/root KEYBOARDTYPE=pc
  KEYTABLE=us rd_LVM_LV=myvg/swap rhgb quiet hugepages=<value-provided-by-script> transparent_hugepage=never
  initrd /initramfs-2.6.32-358.el6.x86_64.img
```

<sup>12</sup> ALERT: Disable Transparent HugePages on SLES11,RHEL6,OEL6 and UEK2 Kernels (DOC ID: 1557478.1)

**NOTE:** Allocating the number of huge pages within the kernel boot command line is the most reliable method due to memory not yet becoming fragmented.<sup>13</sup>

5. Add the oracle soft and hard limits with regards to *memlock* within */etc/security/limits.d/99-grid-oracle-limits.conf* as follows:

```
oracle soft memlock <value-provided-by-script>
oracle hard memlock <value-provided-by-script>
```

6. Reboot the system to ensure the *hugepages* setting takes effect properly.
7. Verify the total number of huge pages on the system with the following command:

```
# cat /proc/meminfo | grep -i hugepages_total
HugePages_Total: <value-provided-by-script>
```

8. Verify the current status of the transparent huge pages is set to *NEVER* via the following command:

```
# cat /sys/kernel/mm/transparent_hugepage/enabled
always [never]
```

**NOTE:** Starting with Oracle Database version 11.2.0.2, the initialization parameter “USE\_LARGE\_PAGES” was introduced to allocate huge pages on a per database use case. The default value for Oracle Database 11.2.0.2 is true, while for Oracle Databases running 11.2.0.3 or higher it is set to auto. For more information on the parameter and its value refer to My Oracle Support<sup>14</sup>.

**NOTE:** Huge pages is not compatible with Automatic Memory Management (AMM).

---

13 <https://www.kernel.org/doc/Documentation/vm/hugetlbpage.txt>

14 USE\_LARGE\_PAGES To Enable HugePages In 11.2 [ID 1392497.1]





## 5 Logging into the Oracle Database 11g Release 2 (11.2.0.3)

This section focuses on ensuring once the Oracle Database 11g Release 2 (11.2.0.3) deployment is complete, one can successfully log into the Oracle database. The following steps provide the details.

As the oracle user,

1. Set the environment variable for *ORACLE\_HOME* with the location of your Oracle Database 11g Release 2 (11.2.0.3) home. This reference architecture sets *ORACLE\_HOME* to */u01/app/oracle/product/11.2.0/dbhome\_1*

```
# export ORACLE_HOME=/u01/app/oracle/product/11.2.0/dbhome_1
# echo $ORACLE_HOME
/u01/app/oracle/product/11.2.0/dbhome_1
```

**NOTE:** There is a bug within Oracle Database 11g Release 2 (11.2.0.3) that requires that the export of *ORACLE\_HOME* not include a trailing forward slash (/).

2. Set the Oracle System ID (*ORACLE\_SID*) used to identify the database.

```
# export ORACLE_SID=db
# echo $ORACLE_SID
db
```

3. Invoke the **sqlplus** binary to log into the Oracle instance as a *sysdba*.

```
# $ORACLE_HOME/bin/sqlplus / as sysdba;
SQL*Plus: Release 11.2.0.3.0 Production on Wed Jun 5 13:55:05 2013
```

```
Copyright (c) 1982, 2011, Oracle. All rights reserved.
```

```
Connected to:
Oracle Database 11g Enterprise Edition Release 11.2.0.3.0 - 64bit Production
With the Partitioning, Automatic Storage Management, OLAP, Data Mining
and Real Application Testing options
```

## 6 Conclusion

Red Hat solutions with Oracle Database 11g Release 2 (11.2.0.3) on Red Hat Enterprise Linux 6 are created to simplify and optimize the deployment process, provide the latest best practices, and protect Oracle Database environments with the use of *SELinux*. The steps and procedures provide system and storage administrators the blueprint required to create a Red Hat | Oracle solution.

For any questions or concerns, please email [refarch-feedback@redhat.com](mailto:refarch-feedback@redhat.com) and ensure to visit the Red Hat Reference Architecture page at <http://www.redhat.com/resourcelibrary/reference-architectures/> to find out about all of our Red Hat solution offerings.



# Appendix A: Revision History

Revision 1.4                                      Tuesday, December 10, 2013      Roger Lopez

- Modified the Section 3.4.4 Optimizing Database Storage using Automatic System Tuning by creating a custom tuned profile that disables THP
- Removed step 6 from Section 4.1.5 Enabling HugePages relating to disabling THP as it is now fixed using the custom profile from Section 3.4.4
- Modified any mention of the use of *limits.conf* from Section 3.3.13 Setting Shell Limits for the Grid and Oracle User to the more appropriate *99-grid-oracle-limits.conf*
- Removed any mention of adding “*session required pam\_limits.so*” to the */etc/pam.d/login* file as the file */etc/pam.d/system-auth* already includes it by default and is not necessary to add it in the */etc/pam.d/login* file
- Appendix K Configuration Files contains the new *enterprise-storage-no-thp* directory for ease of use of tuned profiles
- Miscellaneous grammar corrections within the document

Revision 1.3                                      Friday, August 16, 2013                      Roger Lopez

- Created a new OS Hostname section
- Created a new */etc/resolv.conf* config section
- Added a MOS article note to DBCA section with regards to Flash Recovery Area
- Altered how to disable THP due to tuned
- *fs.file-max* is required for both udev and Oracle ASMLib during Oracle Installation.
- Changed instructions within Section 3.4.3.2 Configuring Oracle ASMLib, now that *oracleasm.pp* is no longer required
- Fixed typos

Revision 1.2                                      Friday July 26, 2013                          Roger Lopez

- Added styling to certain text & fixed typos
- Added steps to Section 3.3.3.1 Oracle ASMLib Alternative: Configuring Udev Rules
- Modified steps to Section 4.1.5 Enabling HugePages that refer to disabling THP & setting the number of huge pages via the kernel boot command line.

Revision 1.1                                      Monday July 8, 2013                          Roger Lopez

- Fixed numbering & alignment of Table of Contents
- Section 2.5, changed label from “Spare Count” to “Hot Spares Available”
- Section 2.7, expanded each port and provided a brief description
- Section 3.1, Added the *bonding.conf* file within */etc/modprobe.d/*
- Section 3.2.5, Provided the definition of dirty data
- Section 3.2.13, Added */etc/profile.d/oracle-grid.sh* shell script for user *ulimits*
- Added Appendix J Sample Kickstart File
- Added Appendix L Troubleshooting ORA-\* Errors

Revision 1.0  
Initial Release

Monday June 24, 2013

Roger Lopez



## Appendix B: Contributors

1. Dan Walsh, technical review of *SELinux oracleasm.pp module*
2. Scott Collier, content review and technical review of Oracle deployment procedures
3. John Herr, content review
4. Aleksandr Brezhnev, content review and technical review of Oracle deployment procedures
5. Yan Fisher, content review
6. John Boero, content review

# Appendix C: DM Multipath Configuration File

```
# This is a basic configuration file with some examples, for device mapper
# multipath.
# For a complete list of the default configuration values, see
# /usr/share/doc/device-mapper-multipath-0.4.9/multipath.conf.defaults
# For a list of configuration options with descriptions, see
# /usr/share/doc/device-mapper-multipath-0.4.9/multipath.conf.annotated
#
# REMEMBER: After updating multipath.conf, you must run
#
# service multipathd reload
#
# for the changes to take effect in multipathd

## By default, devices with vendor = "IBM" and product = "S/390.*" are
## blacklisted. To enable multipathing on these devices, uncomment the
## following lines.
#blacklist_exceptions {
#    device {
#        vendor    "IBM"
#        product   "S/390.*"
#    }
#}

## Use user friendly names, instead of using WWIDs as names.
defaults {
    user_friendly_names yes
}
##
## Here is an example of how to configure some standard options.
##
#
defaults {
    udev_dir                /dev
    polling_interval        10
    path_selector            "round-robin 0"
    path_grouping_policy    multibus
    getuid_callout          "/lib/udev/scsi_id --whitelisted
--device=/dev/%n"
    prio                    alua
    path_checker            readsector0
    rr_min_io               100
    max_fds                 8192
    rr_weight               priorities
    failback                immediate
    no_path_retry           fail
    user_friendly_names     yes
}
##
## The wwid line in the following blacklist section is shown as an example
```



```
## of how to blacklist devices by wwid. The 2 devnode lines are the
## compiled in default blacklist. If you want to blacklist entire types
## of devices, such as all scsi devices, you should use a devnode line.
## However, if you want to blacklist specific devices, you should use
## a wwid line. Since there is no guarantee that a specific device will
## not change names on reboot (from /dev/sda to /dev/sdb for example)
## devnode lines are not recommended for blacklisting specific devices.
##
blacklist {
    wwid 3600508b1001030353434363646301200
    devnode "^(ram|raw|loop|fd|md|dm-|sr|scd|st)[0-9]*"
    devnode "^hd[a-z]"
}
multipaths {
    multipath {
        wwid          3600c0ff000d7e7a899d8515101000000
        alias         db1
    }
    multipath {
        wwid          3600c0ff000dabfe5a7d8515101000000
        alias         db2
    }
    multipath {
        wwid          3600c0ff000d7e7a8dbd8515101000000
        alias         fra
    }
    multipath {
        wwid          3600c0ff000dabfe5f4d8515101000000
        alias         redo
    }
}
#devices {
#    device {
#        vendor      "COMPAQ  "
#        product     "HSV110 (C)COMPAQ"
#        path_grouping_policy multibus
#        getuid_callout "/lib/udev/scsi_id --whitelisted"
#        --device="/dev/%n"
#        path_checker readsector0
#        path_selector "round-robin 0"
#        hardware_handler "0"
#        failback      15
#        rr_weight     priorities
#        no_path_retry queue
#    }
#    device {
#        vendor      "COMPAQ  "
#        product     "MSA1000  "
#        path_grouping_policy multibus
#    }
#}
#}
```

# Appendix D: Iptables Configuration File

```
# Generated by iptables-save v1.4.7 on Thu May  2 17:24:00 2013
*filter
:INPUT ACCEPT [0:0]
:FORWARD ACCEPT [0:0]
:OUTPUT ACCEPT [6747137:1773545794]
-A INPUT -m state --state RELATED,ESTABLISHED -j ACCEPT
-A INPUT -p icmp -j ACCEPT
-A INPUT -i lo -j ACCEPT
-A INPUT -p tcp -m state --state NEW -m tcp --dport 22 -j ACCEPT
-A INPUT -p tcp -m state --state NEW -m tcp --dport 80 -j ACCEPT
-A INPUT -p tcp -m state --state NEW -m tcp --dport 443 -j ACCEPT
-A INPUT -p tcp -m state --state NEW -m tcp --dport 443 -j ACCEPT
-A INPUT -p tcp -m state --state NEW -m tcp -s 10.16.142.54 --dport 1521 -j
ACCEPT
-A INPUT -p tcp -m state --state NEW -m tcp -s 10.16.142.54 --dport 1158 -j
ACCEPT
-A INPUT -j REJECT --reject-with icmp-host-prohibited
-A FORWARD -j REJECT --reject-with icmp-host-prohibited
COMMIT
# Completed on Thu May  2 17:24:00 2013
```





## Appendix E: Huge Pages Script

The following huge pages script is from Tuning Red Hat Enterprise Linux For Oracle & Oracle RAC by Scott Crot, Sr. Consultant, Red Hat<sup>15</sup> and modified to include the values Oracle's soft and hard memlock.

```
#!/bin/bash
KERN=`uname -r | awk -F. '{ printf("%d.%d\n", $1, $2); }'`
# Find out the HugePage size
HPG_SZ=`grep Hugepagesize /proc/meminfo | awk '{print $2}'`
# Start from 1 pages to be on the safe side and guarantee 1 free HugePage
NUM_PG=1
# Cumulative number of pages required to handle the running shared memory
segments
for SEG_BYTES in `ipcs -m | awk '{print $5}' | grep "[0-9][0-9]*"`
do
MIN_PG=`echo "$SEG_BYTES/($HPG_SZ*1024)" | bc -q`
if [ $MIN_PG -gt 0 ]; then
NUM_PG=`echo "$NUM_PG+$MIN_PG+1" | bc -q`
fi
done
# Finish with results
case $KERN in
'2.4') HUGETLB_POOL=`echo "$NUM_PG*$HPG_SZ/1024" | bc -q`;
echo "Recommended setting: vm.hugetlb_pool = $HUGETLB_POOL" ;;
'2.6') MEM_LOCK=`echo "$NUM_PG*$HPG_SZ" | bc -q`;
echo "Recommended setting within the kernel boot command line: hugepages =
$NUM_PG"
echo "Recommended setting within /etc/security/limits.d/99-grid-oracle-
limits.conf: oracle soft memlock $MEM_LOCK"
echo "Recommended setting within /etc/security/limits.d/99-grid-oracle-
limits.conf: oracle hard memlock $MEM_LOCK" ;;
*) echo "Unrecognized kernel version $KERN. Exiting." ;;
esac
```

---

15 Tuning Red Hat Enterprise Linux For Oracle & Oracle RAC by Scott Crot, Sr. Consultant, Red Hat, [http://www.redhat.com/promo/summit/2010/presentations/summit/decoding-the-code/fri/scott-945-tuning/summit\\_jbw\\_2010\\_presentation.pdf](http://www.redhat.com/promo/summit/2010/presentations/summit/decoding-the-code/fri/scott-945-tuning/summit_jbw_2010_presentation.pdf)

# Appendix F: Oracle Database Package Requirements Text File

```
cloog-pp1
compat-libcap1
compat-libstdc++-33
cpp
gcc
gcc-c++
glibc-devel
glibc-headers
kernel-headers
ksh
libXmu
libXt
libXv
libXxf86dga
libXxf86misc
libXxf86vm
libaio-devel
libdmx
libstdc++-devel
mpfr
make
ppl
xorg-x11-utils
xorg-x11-xauth
```



## Appendix G: Kernel Parameters

```
vm.swappiness = 0
vm.dirty_background_ratio = 3
vm.dirty_ratio = 80
vm.dirty_expire_centisecs = 500
vm.dirty_writeback_centisecs = 100
kernel.shmmax = 68719476736
kernel.shmall = 4294967296
kernel.shmmni = 4096
kernel.sem = 250 32000 100 128
# fs.file-max needs to be set to at least 6815744 for Oracle Installation.
fs.file-max = 6815744
fs.aio-max-nr = 1048576
net.ipv4.ip_local_port_range = 9000 65500
net.core.rmem_default = 262144
net.core.rmem_max = 4194304
net.core.wmem_default = 262144
net.core.wmem_max = 1048576
```

## Appendix H: Limits Configuration File (99-grid-oracle-limits.conf)

```
oracle soft nproc 2047
oracle hard nproc 16384
oracle soft nofile 1024
oracle hard nofile 65536
oracle soft stack 10240
oracle hard stack 32768
oracle soft memlock <value-provided-by-script>
oracle hard memlock <value-provided-by-script>

grid soft nproc 2047
grid hard nproc 16384
grid soft nofile 1024
grid hard nofile 65536
grid soft stack 10240
grid hard stack 32768
```



## Appendix I: 99-oracle-asmdevices.rules

```
KERNEL=="dm-*",ENV{DM_UUID}=="<enter-value-according-to-your-  
environment>",OWNER="grid",GROUP="asmadmin",MODE="0660"  
KERNEL=="dm-*",ENV{DM_UUID}=="<enter-value-according-to-your-  
environment>",OWNER="grid",GROUP="asmadmin",MODE="0660"  
KERNEL=="dm-*",ENV{DM_UUID}=="<enter-value-according-to-your-  
environment>",OWNER="grid",GROUP="asmadmin",MODE="0660"  
KERNEL=="dm-*",ENV{DM_UUID}=="<enter-value-according-to-your-  
environment>",OWNER="grid",GROUP="asmadmin",MODE="0660"
```

# Appendix J: Sample Kickstart File

```
# Red Hat | Oracle Solutions Kickstart Script

install
url --url=<place-distro-url-here>
lang en_US.UTF-8
keyboard us
network --onboot yes --device em1 --mtu=1500 --bootproto dhcp
rootpw redhat
# Reboot after installation
reboot
authconfig --enablemd5 --enablesshadow
selinux --enforcing
timezone America/New_York
bootloader --location=mbr --driveorder=sda --append="crashkernel=auto rhgb
quiet"
# The following is the partition information you requested
# Note that any partitions you deleted are not expressed
# here so unless you clear all partitions first, this is
# not guaranteed to work
clearpart --all

volgroup myvg --pesize=32768 pv.008002
logvol /home --fstype=ext4 --name=home --vgname=myvg --size=8192
logvol / --fstype=ext4 --name=root --vgname=myvg --size=15360
logvol swap --name=swap --vgname=myvg --size=16400
logvol /tmp --fstype=ext4 --name=tmp --vgname=myvg --size=4096
logvol /u01 --fstype=ext4 --name=u01 --vgname=myvg --size=51200
logvol /usr --fstype=ext4 --name=usr --vgname=myvg --size=5120
logvol /var --fstype=ext4 --name=var --vgname=myvg --size=8192

part /boot --fstype=ext4 --size=256
part pv.008002 --grow --size=1000

%packages
@Base
@Core
```



## Appendix K: Configuration Files

All configuration files can be downloaded from the Red Hat customer portal<sup>16</sup>. A listing of all the files and a brief description can be seen on the **Table 6.1: Configuration Files**. Some of the configuration files require input with the proper information pertaining to your environment.

Files	Description
req-rpm.txt	The required RPMs to deploy Oracle.
huge_page_settings.sh	Script that provides the proper hugepage values to set.
multipath.conf	Device Mapper Multipath configuration file.
sysctl.conf	Configuration file for the kernel parameters
99-grid-oracle-limits.conf	Configuration file to set limits for a user.
selinux-policy	Version: 3.7.19-211. This version ensures that oracleasm works properly with <i>SELinux</i> enabled.
selinux-policy-targeted	Version: 3.7.19-211. This version ensures that oracleasm works properly with <i>SELinux</i> enabled.
99-oracle-asmdevices.rules	<i>udev</i> configuration file for Oracle ASM disks
iptables	iptables configuration
bonding.conf	<i>/etc/modprobe.d/</i> bonding configuration file
oracle-grid.sh	Shell script used to set user limits
sample-ks.cfg	Sample Kickstart File
enterprise-storage-no-thp	Directory of the custom tuned profile enterprise-sorage-no-thp
CHANGELOG	Listing of the latest changes made to the .tar.gz file

**Table 6.1: Configuration Files**

<sup>16</sup> <https://access.redhat.com/site/node/395013/40/1>

# Appendix L: Troubleshooting ORA-\* Errors

This section focuses on using the command line tool, Automatic Diagnostic Repository Command Interpreter (*ADRCI*), to troubleshoot Oracle database related errors. *ADRCI* was introduced in Oracle Database 11g in order to help users diagnose errors within their Oracle database environments and provide health reports if an issue should arise. The following example shows how one could troubleshoot an Oracle database instance error using the *ADRCI* tool.

**NOTE:** The following steps are intended to produce an ORA-07445 error that can be troubleshooted using the *ADRCI* tool. Do not attempt on a Oracle Database Production environment. The following is for demonstration purposes only and intended only to show how to troubleshoot ORA-\* related errors using the *ADRCI* tool.

1. In order to create an ORA-07445 error, an essential Oracle process will be killed via the following commands:

```
# ps -A --format pid,args | grep ora_dbrm | grep -v grep
27121 ora_dbrm_db
# kill -SEGV 27121
```

2. Export the ORACLE\_HOME via the command:

```
# export ORACLE_HOME=/u01/app/oracle/product/11.2.0/dbhome_1
```

3. Start the *ADRCI* command tool via the command:

```
# $ORACLE_HOME/bin/adrci

ADRCI: Release 11.2.0.3.0 - Production on Mon Jul 1 19:42:58 2013

Copyright (c) 1982, 2011, Oracle and/or its affiliates. All rights
reserved.

ADR base = "/u01/app/oracle"
adrci>
```

4. At the *ADRCI* prompt, show Oracle Home's available via the command:

```
adrci> show home
ADR Homes:
diag/rdbms/db/db
```

**NOTE:** If more than one Oracle Home is available, one must specify a particular Oracle Database Home. An example on how to set to a particular Oracle Database Home is as follows:

```
adrci> set home diag/rdbms/db/db
```

5. At the *ADRCI* prompt, run the following command to see the last 50 entries in the alert log:

```
adrci> show alert -tail -f
[ ... Output Abbreviated ... ]
Exception [type: SIGSEGV, unknown code] [ADDR:0xD43100006BE0]
[PC:0x3D6CCEAFCA, semtimedop()+10] [exception issued by pid: 27616, uid:
54321] [flags: 0x0, count: 1]
Errors in file /u01/app/oracle/diag/rdbms/db/db/trace/db_dbrm_27121.trc
(incident=24057):
```





```
ORA-07445: exception encountered: core dump [semtimedop()+10] [SIGSEGV]
[ADDR:0xD43100006BE0] [PC:0x3D6CCEAFCA] [unknown code] []
Incident details in:
/u01/app/oracle/diag/rdbms/db/db/incident/incdir_24057/db_dbrm_27121_i240
57.trc
Use ADRCI or Support Workbench to package the incident.
See Note 411.1 at My Oracle Support for error and packaging details.
```

**NOTE:** In this particular case, we are looking for an ORA-07445 within the alert log as seen above. However, this step is just to confirm what is seen in the future *ADRCI* steps. To exit the alert log, CTRL+C.

6. Within the *ADRCI*, there are two key terms to be aware of, problem and incident. An incident is a particular time when a problem occurred. For example, it is possible for an Oracle process to crash at different times with the same ORA-07445. The multiple occurrences of the crash are incidents, while the problem is still the ORA-07445 error. In order to view the problem, the following *ADRCI* command needs to be run.

```
adrci> show problem
ADR Home = /u01/app/oracle/diag/rdbms/db/db:
*****
PROBLEM_ID          PROBLEM_KEY          LAST_INCIDENT          LASTINC_TIME
-----
1      ORA 7445 [semtimedop()+10]      24057      2013-07-01 19:51:42.408000
-04:00
```

7. In order to view how many incidents, the following *ADRCI* command needs to be run. In this example, I only have one incident in which the ORA-07445 problem occurred.

```
adrci> show incident
ADR Home = /u01/app/oracle/diag/rdbms/db/db:
*****
INCIDENT_ID          PROBLEM_KEY          CREATE_TIME
-----
24057      ORA 7445 [semtimedop()+10]      2013-07-01 19:51:42.408000 -04:00
1 rows fetched
```

8. In order to view the incident in more detail, run the following command:

```
adrci> show incident -mode detail -p "incident_id=24057"
ADR Home = /u01/app/oracle/diag/rdbms/db/db:
*****

*****
INCIDENT INFO RECORD 1
*****

INCIDENT_ID          24057
STATUS               ready
CREATE_TIME          2013-07-01 19:51:42.408000 -04:00
PROBLEM_ID           1
CLOSE_TIME           <NULL>
FLOOD_CONTROLLED     none
ERROR_FACILITY       ORA
ERROR_NUMBER         7445
```

```

ERROR_ARG1          semtimedop()+10
ERROR_ARG2          SIGSEGV
ERROR_ARG3          ADDR:0xD43100006BE0
[ ... Output Abbreviated ... ]
OWNER_ID            1
INCIDENT_FILE      /u01/app/oracle/diag/rdbms/db/db/trace/db_dbrm_27121.trc
OWNER_ID            1
INCIDENT_FILE
/u01/app/oracle/diag/rdbms/db/db/incident/incdir_24057/db_dbrm_27121_i24057.trc
1 rows fetched

```

**NOTE:** The two parameters of importance here are the `PROBLEM_ID` and `INCIDENT_FILE`.

- When looking at the incident in further detail, the following incident file can be examined further via the following command:

```

adrci> show trace
/u01/app/oracle/diag/rdbms/db/db/incident/incdir_24057/db_dbrm_27121_i24057.trc
/
u01/app/oracle/diag/rdbms/db/db/incident/incdir_24057/db_dbrm_27121_i24057.trc
-----
-----
LEVEL PAYLOAD
-----
-----
Dump file
/u01/app/oracle/diag/rdbms/db/db/incident/incdir_24057/db_dbrm_27121_i24057.trc
Oracle Database 11g Enterprise Edition Release 11.2.0.3.0 - 64bit
Production
With the Partitioning, Automatic Storage Management, OLAP, Data Mining
and Real Application Testing options
ORACLE_HOME = /u01/app/oracle/product/11.2.0/dbhome_1
System name:      Linux
Node name:        db-oracle-node1.cloud.lab.eng.bos.redhat.com
Release:  2.6.32-358.el6.x86_64
Version:  #1 SMP Tue Jan 29 11:47:41 EST 2013
Machine:  x86_64
Instance name:   db
Redo thread mounted by this instance: 1
Oracle process number: 7
Unix process pid: 27121, image: ?

*** 2013-07-01 19:51:42.411
*** SESSION ID:(113.1) 2013-07-01 19:51:42.411
*** CLIENT ID:() 2013-07-01 19:51:42.411
*** SERVICE NAME:(SYS$BACKGROUND) 2013-07-01 19:51:42.411
*** MODULE NAME:() 2013-07-01 19:51:42.411
*** ACTION NAME:() 2013-07-01 19:51:42.411

Dump continued from file:
/u01/app/oracle/diag/rdbms/db/db/trace/db_dbrm_27121.trc
1> ***** Error Stack *****
ORA-07445: exception encountered: core dump [semtimedop()+10] [SIGSEGV]

```



```
[ADDR:0xD43100006BE0] [PC:0x3D6CCEAFCA] [unknown code] []
1< ***** Error Stack *****
1> ***** Dump for incident 24057 (ORA 7445 [semtimedop()+10]) *****
2> ***** Beginning of Customized Incident Dump(s) *****
      Exception [type: SIGSEGV, unknown code] [ADDR:0xD43100006BE0]
[PC:0x3D6CCEAFCA, semtimedop()+10] [exception issued by pid: 27616, uid:
54321]
[ ... Output Abbreviated ... ]
```

10. While this concludes how to examine trace files that pertain to a particular ORA error using *ADRCI*; if the issue cannot be solved by the end user, the *ADRCI* provides the *Incident Packaging Service* (IPS) tool to ZIP the necessary trace files based on the problem. It can then be sent to support for further debugging. To create the appropriate ZIP file, use the following commands:

```
adrci> ips create package problem 1 correlate all
Created package 1 based on problem id 1, correlation level all
```

**NOTE:** Problem 1 is the Problem\_ID found step 6.

```
adrci> ips generate package 1 in "/home/oracle"
Generated package 1 in file
/home/oracle/ORA7445se_20130701212832_COM_1.zip, mode complete
```

**NOTE:** Package 1 is the package ID captured from the ips create output command.

For more information about *ADRCI*, please visit the [http://docs.oracle.com/cd/E11882\\_01/server.112/e25494/diag001.htm](http://docs.oracle.com/cd/E11882_01/server.112/e25494/diag001.htm)

# Appendix M: References

**TECH: Unix Semaphores and Shared Memory Explained [ID 15566.1]**

[http://docs.oracle.com/cd/E11882\\_01/install.112/e24321/pre\\_install.htm](http://docs.oracle.com/cd/E11882_01/install.112/e24321/pre_install.htm)

**Oracle Grid Infrastructure, Oracle Documentation**

[http://docs.oracle.com/cd/E18248\\_01/doc/install.112/e16763/oraclerestart.htm#CHDFDAIG](http://docs.oracle.com/cd/E18248_01/doc/install.112/e16763/oraclerestart.htm#CHDFDAIG)

**Tuning Red Hat Enterprise Linux For Oracle & Oracle RAC by Scott Crot, Sr. Consultant, Red Hat**

[http://www.redhat.com/promo/summit/2010/presentations/summit/decoding-the-code/fri/scott-945-tuning/summit\\_jbw\\_2010\\_presentation.pdf](http://www.redhat.com/promo/summit/2010/presentations/summit/decoding-the-code/fri/scott-945-tuning/summit_jbw_2010_presentation.pdf)

**Linux OS Installation with Reduced Set of Packages for Running Oracle Database Server [ID 728346.1]**

[https://support.oracle.com/epmos/faces/DocumentDisplay?\\_afzLoop=290805959329203&id=728346.1&\\_adf.ctrl-state=13886txzey\\_67](https://support.oracle.com/epmos/faces/DocumentDisplay?_afzLoop=290805959329203&id=728346.1&_adf.ctrl-state=13886txzey_67)

**Installing 11.2.0.3 32-bit (x86) or 64-bit (x86-64) on RHEL6 Reports That Packages "elfutils-libelf-devel-0.97" and "pdksh-5.2.14" are missing (PRVF-7532) [ID 1454982.1]**

[https://support.oracle.com/epmos/faces/ui/km/SearchDocDisplay.jspx?returnToSrid=&\\_afzLoop=290981302886992&srnum=&type=DOCUMENT&id=1454982.1&displayIndex=3&\\_afzWindowMode=0&\\_adf.ctrl-state=13886txzey\\_154](https://support.oracle.com/epmos/faces/ui/km/SearchDocDisplay.jspx?returnToSrid=&_afzLoop=290981302886992&srnum=&type=DOCUMENT&id=1454982.1&displayIndex=3&_afzWindowMode=0&_adf.ctrl-state=13886txzey_154)

**USE\_LARGE\_PAGES To Enable HugePages In 11.2 [ID 1392497.1]**

[https://support.oracle.com/epmos/faces/Dashboard?\\_adf.ctrl-state=nvtwimbst\\_252](https://support.oracle.com/epmos/faces/Dashboard?_adf.ctrl-state=nvtwimbst_252)

**Large Pages Information in the Alert Log [ID 1392543.1]**

[https://support.oracle.com/epmos/faces/ui/km/SearchDocDisplay.jspx?\\_adf.ctrl-state=nvtwimbst\\_226](https://support.oracle.com/epmos/faces/ui/km/SearchDocDisplay.jspx?_adf.ctrl-state=nvtwimbst_226)

**Tuning Virtual Memory**

[https://access.redhat.com/site/documentation/en-US/Red\\_Hat\\_Enterprise\\_Linux/6/html/Performance\\_Tuning\\_Guide/s-memory-tunables.html](https://access.redhat.com/site/documentation/en-US/Red_Hat_Enterprise_Linux/6/html/Performance_Tuning_Guide/s-memory-tunables.html)

**Maximum SHMMAX values for Linux x86 and x86-64 [ID 567506.1]**

[https://support.oracle.com/epmos/faces/ui/km/SearchDocDisplay.jspx?\\_adf.ctrl-state=yp0o5bwk6\\_4](https://support.oracle.com/epmos/faces/ui/km/SearchDocDisplay.jspx?_adf.ctrl-state=yp0o5bwk6_4)

**About the Oracle Database Fault Diagnosability Infrastructure**

[http://docs.oracle.com/cd/E11882\\_01/server.112/e25494/diag001.htm](http://docs.oracle.com/cd/E11882_01/server.112/e25494/diag001.htm)

