



Red Hat Ansible Automation Platform 2.3

Red Hat Ansible Automation Platform automation mesh guide

This guide provides information used to deploy automation mesh as part of your Ansible Automation Platform environment

Red Hat Ansible Automation Platform 2.3 Red Hat Ansible Automation Platform automation mesh guide

This guide provides information used to deploy automation mesh as part of your Ansible Automation Platform environment

Legal Notice

Copyright © 2024 Red Hat, Inc.

The text of and illustrations in this document are licensed by Red Hat under a Creative Commons Attribution–Share Alike 3.0 Unported license ("CC-BY-SA"). An explanation of CC-BY-SA is available at

<http://creativecommons.org/licenses/by-sa/3.0/>

. In accordance with CC-BY-SA, if you distribute this document or an adaptation of it, you must provide the URL for the original version.

Red Hat, as the licensor of this document, waives the right to enforce, and agrees not to assert, Section 4d of CC-BY-SA to the fullest extent permitted by applicable law.

Red Hat, Red Hat Enterprise Linux, the Shadowman logo, the Red Hat logo, JBoss, OpenShift, Fedora, the Infinity logo, and RHCE are trademarks of Red Hat, Inc., registered in the United States and other countries.

Linux[®] is the registered trademark of Linus Torvalds in the United States and other countries.

Java[®] is a registered trademark of Oracle and/or its affiliates.

XFS[®] is a trademark of Silicon Graphics International Corp. or its subsidiaries in the United States and/or other countries.

MySQL[®] is a registered trademark of MySQL AB in the United States, the European Union and other countries.

Node.js[®] is an official trademark of Joyent. Red Hat is not formally related to or endorsed by the official Joyent Node.js open source or commercial project.

The OpenStack[®] Word Mark and OpenStack logo are either registered trademarks/service marks or trademarks/service marks of the OpenStack Foundation, in the United States and other countries and are used with the OpenStack Foundation's permission. We are not affiliated with, endorsed or sponsored by the OpenStack Foundation, or the OpenStack community.

All other trademarks are the property of their respective owners.

Abstract

Providing Feedback: If you have a suggestion to improve this documentation, or find an error, please contact technical support at to create an issue on the Ansible Automation Platform Jira project using the Docs component.

Table of Contents

PREFACE	3
MAKING OPEN SOURCE MORE INCLUSIVE	4
CHAPTER 1. PLANNING FOR AUTOMATION MESH IN YOUR RED HAT ANSIBLE AUTOMATION PLATFORM ENVIRONMENT	5
1.1. ABOUT AUTOMATION MESH	5
1.2. CONTROL AND EXECUTION PLANES	5
1.2.1. Control plane	5
1.2.2. Execution plane	6
1.2.3. Peers	6
1.2.4. Defining automation mesh node types	6
CHAPTER 2. SETTING UP AUTOMATION MESH	9
2.1. AUTOMATION MESH INSTALLATION	9
2.2. IMPORTING A CERTIFICATE AUTHORITY (CA) CERTIFICATE	9
CHAPTER 3. AUTOMATION MESH DESIGN PATTERNS	10
3.1. MULTIPLE HYBRID NODES INVENTORY FILE EXAMPLE	10
3.2. SINGLE NODE CONTROL PLANE WITH SINGLE EXECUTION NODE	11
3.3. MINIMUM RESILIENT CONFIGURATION	13
3.4. SEGREGATED LOCAL AND REMOTE EXECUTION CONFIGURATION	14
3.5. MULTI-HOPPED EXECUTION NODE	15
3.6. OUTBOUND ONLY CONNECTIONS TO CONTROLLER NODES	17
CHAPTER 4. DEPROVISIONING INDIVIDUAL NODES OR GROUPS	19
4.1. DEPROVISIONING INDIVIDUAL NODES USING THE INSTALLER	19
4.1.1. Deprovisioning isolated nodes	19
4.2. DEPROVISIONING GROUPS USING THE INSTALLER	20
4.2.1. Deprovisioning isolated instance groups	20

PREFACE

Thank you for your interest in Red Hat Ansible Automation Platform. Ansible Automation Platform is a commercial offering that helps teams manage complex multi-tier deployments by adding control, knowledge, and delegation to Ansible-powered environments.

This guide helps you to understand the installation requirements and processes behind installing Ansible Automation Platform. This document has been updated to include information for the latest release of Ansible Automation Platform.

MAKING OPEN SOURCE MORE INCLUSIVE

Red Hat is committed to replacing problematic language in our code, documentation, and web properties. We are beginning with these four terms: master, slave, blacklist, and whitelist. Because of the enormity of this endeavor, these changes will be implemented gradually over several upcoming releases. For more details, see [our CTO Chris Wright's message](#).

CHAPTER 1. PLANNING FOR AUTOMATION MESH IN YOUR RED HAT ANSIBLE AUTOMATION PLATFORM ENVIRONMENT

The following topics contain information to help plan an automation mesh deployment in your Ansible Automation Platform environment. The following sections explain the concepts that comprise automation mesh in addition to providing examples on how you can design automation mesh topologies. Simple to complex topology examples are included to illustrate the various ways you can deploy automation mesh.

1.1. ABOUT AUTOMATION MESH

Automation mesh is an overlay network intended to ease the distribution of work across a large and dispersed collection of workers through nodes that establish peer-to-peer connections with each other using existing networks.

Red Hat Ansible Automation Platform 2 replaces Ansible Tower and isolated nodes with automation controller and automation hub. Automation controller provides the control plane for automation through its UI, Restful API, RBAC, workflows and CI/CD integration, while automation mesh can be used for setting up, discovering, changing or modifying the nodes that form the control and execution layers.

Automation mesh introduces:

- Dynamic cluster capacity that scales independently, allowing you to create, register, group, ungroup and deregister nodes with minimal downtime.
- Control and execution plane separation that enables you to scale playbook execution capacity independently from control plane capacity.
- Deployment choices that are resilient to latency, reconfigurable without outage, and that dynamically re-reroute to choose a different path when outages may exist. mesh routing changes.
- Connectivity that includes bi-directional, multi-hopped mesh communication possibilities which are Federal Information Processing Standards (FIPS) compliant.

1.2. CONTROL AND EXECUTION PLANES

Automation mesh makes use of unique node types to create both the **control** and **execution** plane. Learn more about the control and execution plane and their node types before designing your automation mesh topology.

1.2.1. Control plane

The **control plane** consists of hybrid and control nodes. Instances in the control plane run persistent automation controller services such as the the web server and task dispatcher, in addition to project updates, and management jobs.

- **Hybrid nodes** - this is the default node type for control plane nodes, responsible for automation controller runtime functions like project updates, management jobs and **ansible-runner** task operations. Hybrid nodes are also used for automation execution.
- **Control nodes** - control nodes run project and inventory updates and system jobs, but not regular jobs. Execution capabilities are disabled on these nodes.

1.2.2. Execution plane

The **execution plane** consists of execution nodes that execute automation on behalf of the control plane and have no control functions. Hop nodes serve to communicate. Nodes in the **execution plane** only run user-space jobs, and may be geographically separated, with high latency, from the control plane.

- **Execution nodes** - Execution nodes run jobs under **ansible-runner** with **podman** isolation. This node type is similar to isolated nodes. This is the default node type for execution plane nodes.
- **Hop nodes** - similar to a jump host, hop nodes will route traffic to other execution nodes. Hop nodes cannot execute automation.

1.2.3. Peers

Peer relationships define node-to-node connections. You can define peers within the **[automationcontroller]** and **[execution_nodes]** groups or using the **[automationcontroller:vars]** or **[execution_nodes:vars]** groups

1.2.4. Defining automation mesh node types

The examples in this section demonstrate how to set the node type for the hosts in your inventory file.

You can set the **node_type** for single nodes in the control plane or execution plane inventory groups. To define the node type for an entire group of nodes, set the **node_type** in the **vars** stanza for the group.

- The allowed values for **node_type** in the control plane **[automationcontroller]** group are **hybrid** (default) and **control**.
- The allowed values for **node_type** in the **[execution_nodes]** group are **execution** (default) and **hop**.

Hybrid node

The following inventory consists of a single hybrid node in the control plane:

```
[automationcontroller]
control-plane-1.example.com
```

Control node

The following inventory consists of a single control node in the control plane:

```
[automationcontroller]
control-plane-1.example.com node_type=control
```

If you set **node_type** to **control** in the **vars** stanza for the control plane nodes, then all of the nodes in control plane are control nodes.

```
[automationcontroller]
control-plane-1.example.com
```

```
[automationcontroller:vars]
node_type=control
```

Execution node

The following stanza defines a single execution node in the execution plane:

```
[execution_nodes]
execution-plane-1.example.com
```

Hop node

The following stanza defines a single hop node and an execution node in the execution plane. The **node_type** variable is set for every individual node.

```
[execution_nodes]
execution-plane-1.example.com node_type=hop
execution-plane-2.example.com
```

If you want to set the **node-type** at the group level, you must create separate groups for the execution nodes and the hop nodes.

```
[execution_nodes]
execution-plane-1.example.com
execution-plane-2.example.com
```

```
[execution_group]
execution-plane-2.example.com
```

```
[execution_group:vars]
node_type=execution
```

```
[hop_group]
execution-plane-1.example.com
```

```
[hop_group:vars]
node_type=hop
```

Peer connections

Create node-to-node connections using the **peers=** host variable. The following example connects **control-plane-1.example.com** to **execution-node-1.example.com** and **execution-node-1.example.com** to **execution-node-2.example.com**:

```
[automationcontroller]
control-plane-1.example.com peers=execution-node-1.example.com
```

```
[automationcontroller:vars]
node_type=control
```

```
[execution_nodes]
execution-node-1.example.com peers=execution-node-2.example.com
execution-node-2.example.com
```

Additional resources

- See the example automation mesh topologies in this guide for more examples of how to implement mesh nodes.

CHAPTER 2. SETTING UP AUTOMATION MESH

Configure the Ansible Automation Platform installer to set up automation mesh for your Ansible environment. Perform additional tasks to customize your installation, such as importing a Certificate Authority (CA) certificate.

2.1. AUTOMATION MESH INSTALLATION

You use the Ansible Automation Platform installation program to set up automation mesh or to upgrade to automation mesh. To provide Ansible Automation Platform with details about the nodes, groups, and peer relationships in your mesh network, you define them in an the **inventory** file in the installer bundle.

Additional Resources

- [Red Hat Ansible Automation Platform Installation Guide](#)
- [Automation Mesh Design Patterns](#)

2.2. IMPORTING A CERTIFICATE AUTHORITY (CA) CERTIFICATE

A Certificate Authority (CA) verifies and signs individual node certificates in an automation mesh environment. You can provide your own CA by specifying the path to the certificate and the private RSA key file in the **inventory** file of your Red Hat Ansible Automation Platform installer.



NOTE

The Ansible Automation Platform installation program generates a CA if you do not provide one.

Procedure

1. Open the **inventory** file for editing.
2. Add the **mesh_ca_keyfile** variable and specify the full path to the private RSA key (**.key**).
3. Add the **mesh_ca_certfile** variable and specify the full path to the CA certificate file (**.crt**).
4. Save the changes to the inventory file.

Example

```
[all:vars]
mesh_ca_keyfile=/tmp/<mesh_CA>.key
mesh_ca_certfile=/tmp/<mesh_CA>.crt
```

With the CA files added to the inventory file, run the installation program to apply the CA. This process copies the CA to the to **/etc/receptor/tls/ca/** directory on each control and execution node on your mesh network.

Additional resources

- [Red Hat Ansible Automation Platform System Requirements](#)

CHAPTER 3. AUTOMATION MESH DESIGN PATTERNS

The automation mesh topologies in this section provide examples you can use to design a mesh deployment in your environment. Examples range from a simple, hybrid node deployment to a complex pattern that deploys numerous automation controller instances, employing several execution and hop nodes.

Prerequisites

- You reviewed conceptual information on node types and relationships

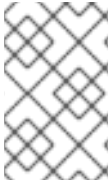

NOTE

The following examples include images that illustrate the mesh topology. The arrows in the images indicate the direction of peering. After peering is established, the connection between the nodes allows bidirectional communication.

3.1. MULTIPLE HYBRID NODES INVENTORY FILE EXAMPLE

This example inventory file deploys a control plane consisting of multiple hybrid nodes. The nodes in the control plane are automatically peered to one another.

```
[automationcontroller]
aap_c_1.example.com
aap_c_2.example.com
aap_c_3.example.com
```

The following image displays the topology of this mesh network.

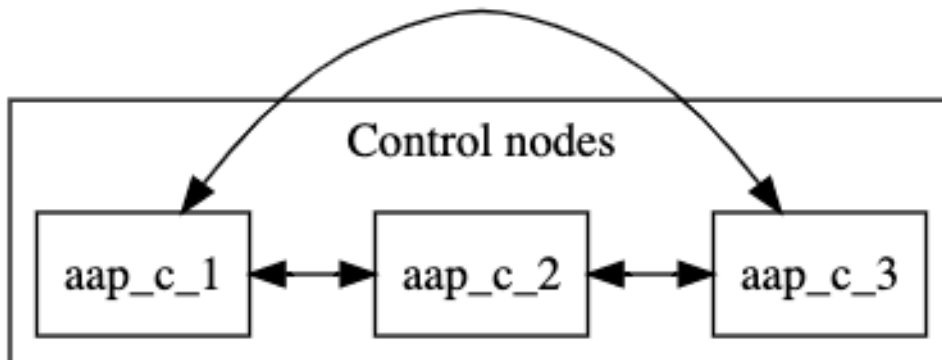

The default **node_type** for nodes in the control plane is **hybrid**. You can explicitly set the **node_type** of individual nodes to **hybrid** in the **[automationcontroller group]**:

```
[automationcontroller]
aap_c_1.example.com node_type=hybrid
aap_c_2.example.com node_type=hybrid
aap_c_3.example.com node_type=hybrid
```

Alternatively, you can set the **node-type** of all nodes in the **[automationcontroller]** group. When you add new nodes to the control plane they are automatically set to hybrid nodes.

```
[automationcontroller]
```

```
aap_c_1.example.com  
aap_c_2.example.com  
aap_c_3.example.com
```

```
[automationcontroller:vars]  
node_type=hybrid
```

If you think that you might add control nodes to your control plane in future, it is better to define a separate group for the hybrid nodes, and set the **node-type** for the group:

```
[automationcontroller]  
aap_c_1.example.com  
aap_c_2.example.com  
aap_c_3.example.com
```

```
[hybrid_group]  
aap_c_1.example.com  
aap_c_2.example.com  
aap_c_3.example.com
```

```
[hybrid_group:vars]  
node_type=hybrid
```

3.2. SINGLE NODE CONTROL PLANE WITH SINGLE EXECUTION NODE

This example inventory file deploys a single-node control plane and establishes a peer relationship to an execution node.

```
[automationcontroller]  
aap_c_1.example.com
```

```
[automationcontroller:vars]  
node_type=control  
peers=execution_nodes
```

```
[execution_nodes]  
aap_e_1.example.com
```

The following image displays the topology of this mesh network.

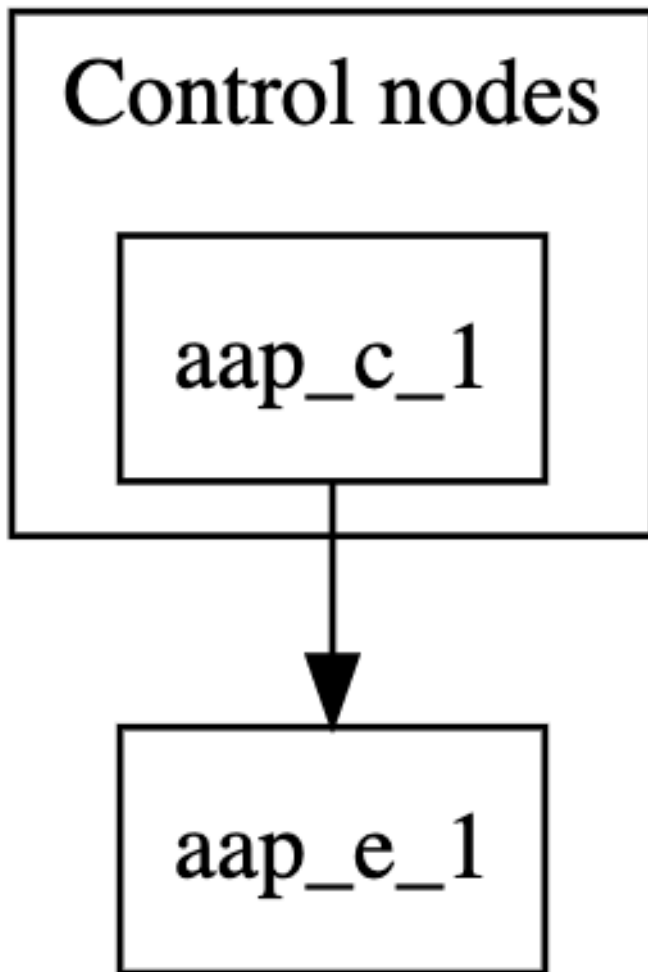

The **[automationcontroller]** stanza defines the control nodes. If you add a new node to the automationcontroller group, it will automatically peer with the **aap_c_1.example.com** node.

The **[automationcontroller:vars]** stanza sets the node type to **control** for all nodes in the control plane and defines how the nodes peer to the execution nodes:

- If you add a new node to the **execution_nodes** group, the control plane nodes automatically peer to it.
- If you add a new node to the **automationcontroller** group, the node type is set to **control**.

The **[execution_nodes]** stanza lists all the execution and hop nodes in the inventory. The default node type is **execution**. You can specify the node type for an individual node:

```
[execution_nodes]
aap_e_1.example.com node_type=execution
```

Alternatively, you can set the `node_type` of all execution nodes in the **[execution_nodes]** group. When you add new nodes to the group, they are automatically set to execution nodes.

```
[execution_nodes]
aap_e_1.example.com

[execution_nodes:vars]
node_type=execution
```

If you plan to add hop nodes to your inventory in future, it is better to define a separate group for the execution nodes, and set the **node_type** for the group:

```
[execution_nodes]
aap_e_1.example.com

[local_execution_group]
aap_e_1.example.com

[local_execution_group:vars]
node_type=execution
```

3.3. MINIMUM RESILIENT CONFIGURATION

This example inventory file deploys a control plane consisting of two control nodes, and two execution nodes. All nodes in the control plane are automatically peered to one another. All nodes in the control plane are peered with all nodes in the **execution_nodes** group. This configuration is resilient because the execution nodes are reachable from all control nodes.

The capacity algorithm determines which control node is chosen when a job is launched. Refer to [Automation controller Capacity Determination and Job Impact](#) in the *Automation Controller User Guide* for more information.

The following inventory file defines this configuration.

```
[automationcontroller]
aap_c_1.example.com
aap_c_2.example.com

[automationcontroller:vars]
node_type=control
peers=execution_nodes

[execution_nodes]
aap_e_1.example.com
aap_e_1.example.com
```

The **[automationcontroller]** stanza defines the control nodes. All nodes in the control plane are peered to one another. If you add a new node to the **automationcontroller** group, it will automatically peer with the original nodes.

The **[automationcontroller:vars]** stanza sets the node type to **control** for all nodes in the control plane and defines how the nodes peer to the execution nodes:

- If you add a new node to the **execution_nodes** group, the control plane nodes automatically peer to it.
- If you add a new node to the **automationcontroller** group, the node type is set to **control**.

The following image displays the topology of this mesh network.

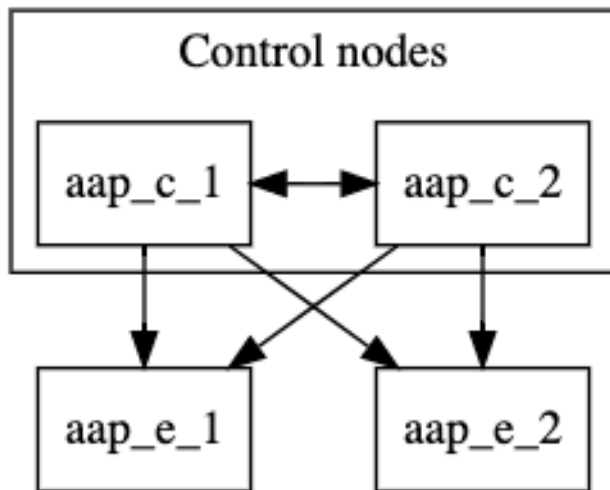

3.4. SEGREGATED LOCAL AND REMOTE EXECUTION CONFIGURATION

This configuration adds a hop node and a remote execution node to the resilient configuration. The remote execution node is reachable from the hop node.

You can use this setup if you are setting up execution nodes in a remote location, or if you need to run automation in a DMZ network.

```

[automationcontroller]
aap_c_1.example.com
aap_c_2.example.com

[automationcontroller:vars]
node_type=control
peers=instance_group_local

[execution_nodes]
aap_e_1.example.com
aap_e_2.example.com
aap_h_1.example.com
aap_e_3.example.com

[instance_group_local]
aap_e_1.example.com
aap_e_2.example.com

[hop]
aap_h_1.example.com

[hop:vars]
peers=automationcontroller

[instance_group_remote]
aap_e_3.example.com

[instance_group_remote:vars]
peers=hop
  
```

The following image displays the topology of this mesh network.

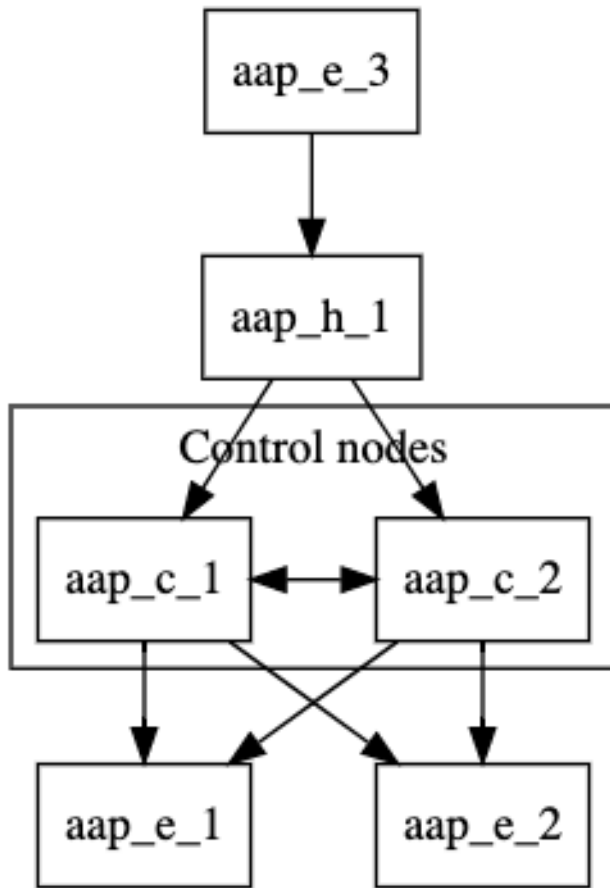

The `[automationcontroller:vars]` stanza sets the node types for all nodes in the control plane and defines how the control nodes peer to the local execution nodes:

- All nodes in the control plane are automatically peered to one another.
- All nodes in the control plane are peered with all local execution nodes.

If the name of a group of nodes begins with `instance_group_`, the installer recognises it as an instance group and adds it to the Ansible Automation Platform user interface.

3.5. MULTI-HOPPED EXECUTION NODE

In this configuration, resilient controller nodes are peered with resilient local execution nodes. Resilient local hop nodes are peered with the controller nodes. A remote execution node and a remote hop node are peered with the local hop nodes.

You can use this setup if you need to run automation in a DMZ network from a remote network.

```

[automationcontroller]
aap_c_1.example.com
aap_c_2.example.com
aap_c_3.example.com

[automationcontroller:vars]
node_type=control
peers=instance_group_local
  
```

```
[execution_nodes]
aap_e_1.example.com
aap_e_2.example.com
aap_e_3.example.com
aap_e_4.example.com
aap_h_1.example.com node_type=hop
aap_h_2.example.com node_type=hop
aap_h_3.example.com node_type=hop

[instance_group_local]
aap_e_1.example.com
aap_e_2.example.com

[instance_group_remote]
aap_e_3.example.com

[instance_group_remote:vars]
peers=local_hop

[instance_group_multi_hop_remote]
aap_e_4.example.com

[instance_group_multi_hop_remote:vars]
peers=remote_multi_hop

[local_hop]
aap_h_1.example.com
aap_h_2.example.com

[local_hop:vars]
peers=automationcontroller

[remote_multi_hop]
aap_h_3 peers=local_hop
```

The following image displays the topology of this mesh network.

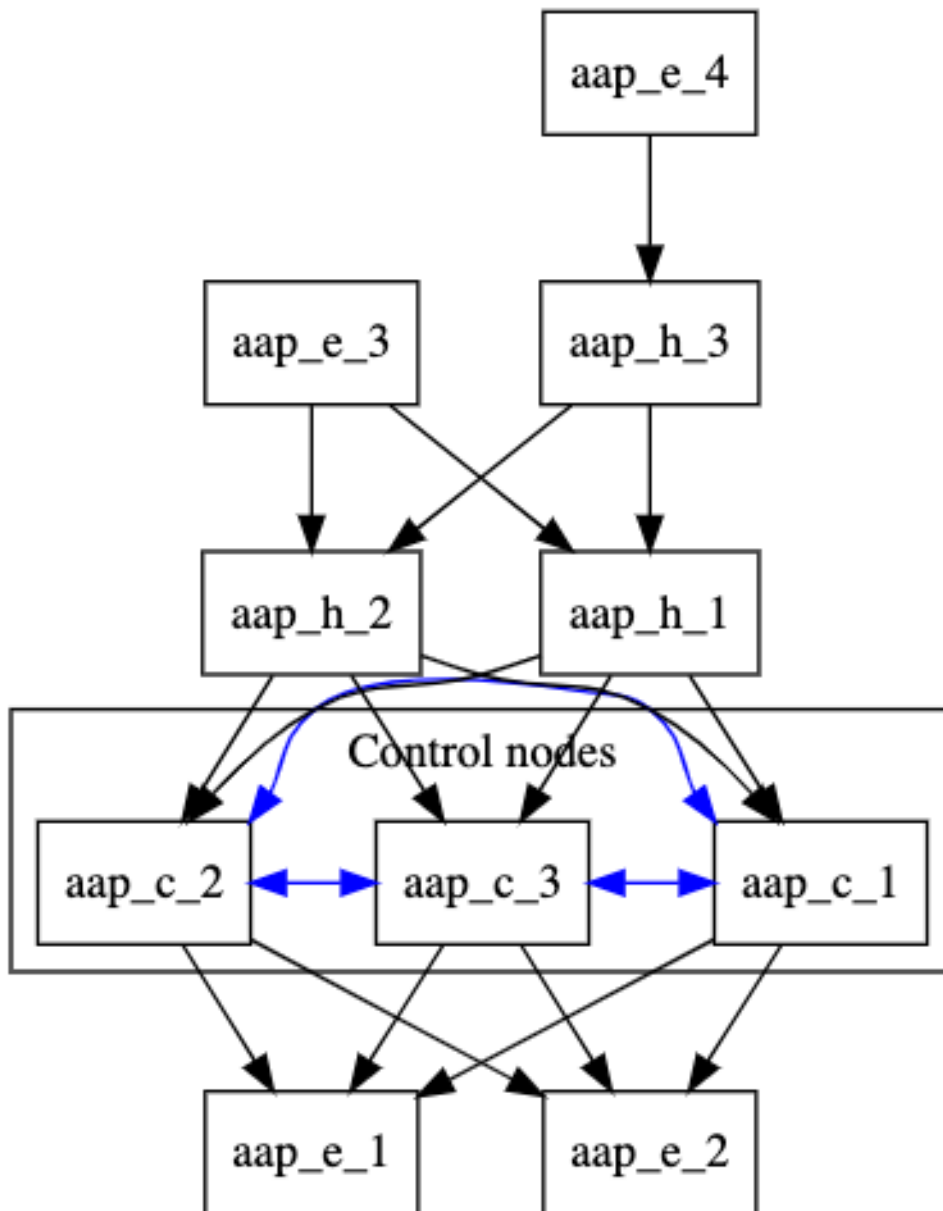

The `[automationcontroller:vars]` stanza sets the node types for all nodes in the control plane and defines how the control nodes peer to the local execution nodes:

- All nodes in the control plane are automatically peered to one another.
- All nodes in the control plane are peered with all local execution nodes.

The `[local_hop:vars]` stanza peers all nodes in the `[local_hop]` group with all the control nodes.

If the name of a group of nodes begins with `instance_group_`, the installer recognises it as an instance group and adds it to the Ansible Automation Platform user interface.

3.6. OUTBOUND ONLY CONNECTIONS TO CONTROLLER NODES

This example inventory file deploys a control plane consisting of two control nodes, and several execution nodes. Only outbound connections are allowed to the controller nodes. All nodes in the 'execution_nodes' group are peered with all nodes in the controller plane.

```
[automationcontroller]
controller-[1:2].example.com
```

```
[execution_nodes]
execution-[1:5].example.com
```

```
[execution_nodes:vars]
# connection is established *from* the execution nodes *to* the automationcontroller
peers=automationcontroller
```

The following image displays the topology of this mesh network.

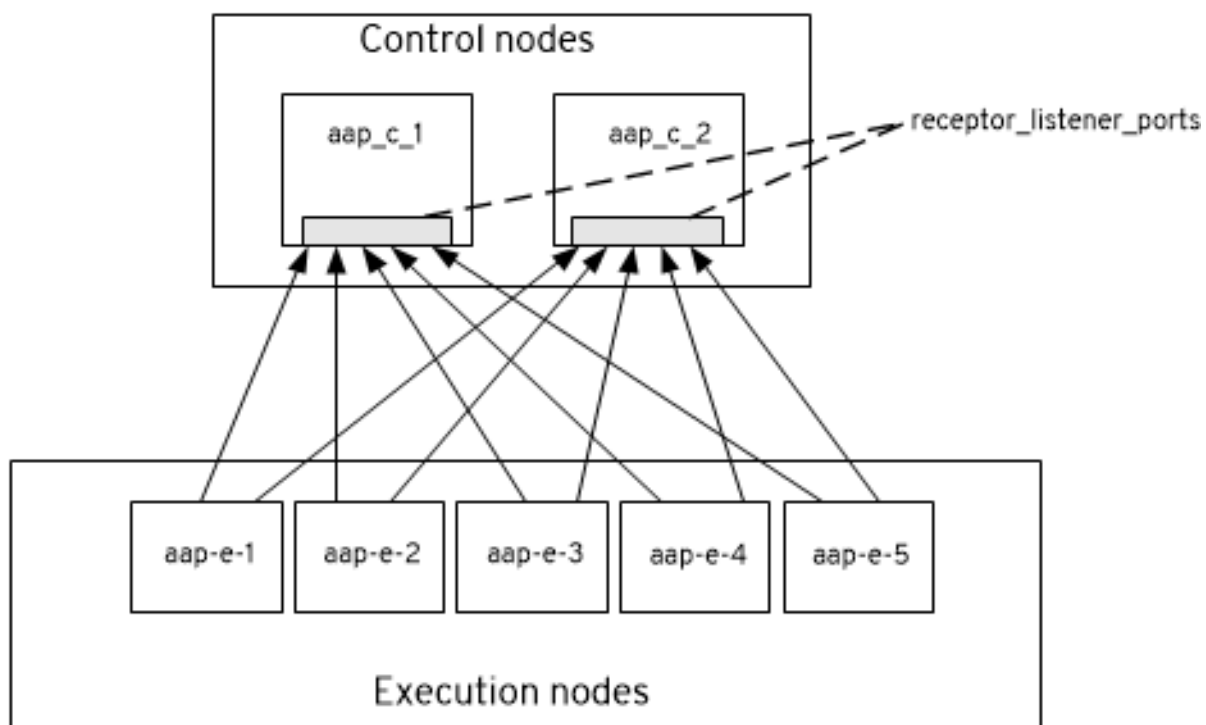

CHAPTER 4. DEPROVISIONING INDIVIDUAL NODES OR GROUPS

You can deprovision automation mesh nodes and instance groups using the Ansible Automation Platform installer. The procedures in this section describe how to deprovision specific nodes or entire groups, with example inventory files for each procedure.

4.1. DEPROVISIONING INDIVIDUAL NODES USING THE INSTALLER

You can deprovision nodes from your automation mesh using the Ansible Automation Platform installer. Edit the **inventory** file to mark the nodes to deprovision, then run the installer. Running the installer also removes all configuration files and logs attached to the node.



NOTE

You can deprovision any of your inventory's hosts except for the first host specified in the **[automationcontroller]** group.

Procedure

- Append **node_state=deprovision** to nodes in the installer file you want to deprovision.

Example

This example inventory file deprovisions two nodes from an automation mesh configuration.

```
[automationcontroller]
126-addr.tatu.home ansible_host=192.168.111.126 node_type=control
121-addr.tatu.home ansible_host=192.168.111.121 node_type=hybrid routable_hostname=121-
addr.tatu.home
115-addr.tatu.home ansible_host=192.168.111.115 node_type=hybrid node_state=deprovision

[automationcontroller:vars]
peers=connected_nodes

[execution_nodes]
110-addr.tatu.home ansible_host=192.168.111.110 receptor_listener_port=8928
108-addr.tatu.home ansible_host=192.168.111.108 receptor_listener_port=29182
node_state=deprovision
100-addr.tatu.home ansible_host=192.168.111.100 peers=110-addr.tatu.home node_type=hop
```

4.1.1. Deprovisioning isolated nodes

You have the option to manually remove any isolated nodes using the **awx-manage** deprovisioning utility.



WARNING

Use the deprovisioning command to remove only isolated nodes that have not migrated to execution nodes. To deprovision execution nodes from your automation mesh architecture, use the [installer method](#) instead.

Procedure

1. Shut down the instance:

```
$ automation-controller-service stop
```

2. Run the deprovision command from another instance, replacing **host_name** with the name of the node as listed in the inventory file:

```
$ awx-manage deprovision_instance --hostname=<host_name>
```

4.2. DEPROVISIONING GROUPS USING THE INSTALLER

You can deprovision entire groups from your automation mesh using the Ansible Automation Platform installer. Running the installer will remove all configuration files and logs attached to the nodes in the group.



NOTE

You can deprovision any hosts in your inventory except for the first host specified in the **[automationcontroller]** group.

Procedure

- Add **node_state=deprovision** to the [group:vars] associated with the group you wish to deprovision.

Example

```
[execution_nodes]
execution-node-1.example.com peers=execution-node-2.example.com
execution-node-2.example.com peers=execution-node-3.example.com
execution-node-3.example.com peers=execution-node-4.example.com
execution-node-4.example.com peers=execution-node-5.example.com
execution-node-5.example.com peers=execution-node-6.example.com
execution-node-6.example.com peers=execution-node-7.example.com
execution-node-7.example.com
```

```
[execution_nodes:vars]
node_state=deprovision
```

4.2.1. Deprovisioning isolated instance groups

You have the option to manually remove any isolated instance groups using the **awx-manage** deprovisioning utility.



WARNING

Use the deprovisioning command to only remove isolated instance groups. To deprovision instance groups from your automation mesh architecture, use the [installer method](#) instead.

Procedure

- Run the following command, replacing **<name>** with the name of the instance group:

```
$ awx-manage unregister_queue --queuename=<name>
```